

A large, detailed industrial valve with a handwheel, set against a dark blue background on the left side of the page.

**Innovations designed
to improve operations
profitability**

YDB VALVE LLP

Khan Real Industrial Estate, N. H. 08,
Vasai Phata, Vasai (E), Dist Palghar - 401208.
Tel.: +91 8087010270

www.ydbvalves.com



About us

YDB VALVES LLP, a pioneer manufacturing company having good experience in the designing and manufacturing of a new concept instrumentation Valves: Manifolds, Monoflanges, SBB & DBB Valves both in needle and ball types, Floating and Trunnion design Ball Valves, strictly produced in according to the most stringent quality standards of safety and efficiency.

We have a fully well-equipped modern in-house manufacturing facility using CNC lathes, VMC, etc. with highly motivated team and up to date technology assisting us to achieve reliable products at competitive price with better product flexibility, consistency and optimum service.

Our experience in the understanding of applications requirements, combined with our high flexibility, allows us to develop customized solutions designed for customers' specific needs.

Our products are machined from the materials CF8M, SS316, SS316L, Duplex, Super Duplex, Monel, Inconel, etc.

Moreover, our valves production can be completed with complementary accessories, something that makes YDB VALVES a favorite and reliable partner for those companies that supply 'packages' of various matching goods. Our products are widely use in the Chemical, Petrochemical, Oil & Gas, Off-Shore, On-Shore, Power Generation, Naval industries, etc., used as components of plants and machineries with a high technological value.

Primary Isolation Valve Application

- Chemical
- Pharmaceutical
- Marine
- Packaging
- Printing Industries
- Architectural
- Electronic
- Power Generation
- Laboratory
- Oil and Gas
- Petro-Chemical
- Power

Our Company



We have well equipped modern manufacturing facility with good motivated skilled experience engineering and production staff. We manufacture each and every component of our products using CNC Lathes, Vertical Machining Centre, Manual Lathes Machine etc. Within given tolerances by closely monitoring critical dimensions, surface finishes, run out, sharp edges etc.



After referring and meeting the requirements as per drawing, under rigid quality controlled procedures approved to ISO 9001: 2015 which ensures consistent quality and high performance products.

Gate Valve
Cast Steel Gate Valve
Forged Steel Gate Valve
Pressure Seal, Cast Steel Gate Valve
Cryogenic Gate Valve

Gate Valve Series



The open-close member of the gate valve is the wedge disc, the moving direction of which is perpendicular to that of the fluid. The gate valve can be fully opened or closed and can not work as regulation and throttle. The wedge disc holds two sealing faces and the most common mode is the two sealing faces form a wedge type, with the wedge angle varying from the parameters, usually as 50 and as 252° when the medium temperature is not high. When a hard-seal gate valve is closed, the sealing face can be sealed only with the medium pressure, that means pressing the sealing face of the wedge disc by means of the medium pressure onto the seat ring on the other side to ensure the sealing of it, just as the self-sealing. While most of the gate valves are sealed in a forced way, i.e. when the valve is closed, the wedge disc is externally forced to be pressed onto the seat ring so as to ensure the tightness of the sealing face. This valve uses the compensating action from the micro- elastic deformation produced with the elastic wedge disc to get a good sealing effect and features light open-close, reliable sealing, good elastic memory and a long duration etc. notable advantages and can be used as a regulation and cut-off device for the pipeline in rap water, sewage, construction, petroleum, chemical, food, medicine, light-textile industry, electric power, ship, metallurgy, energy system etc. trades.

Design

ADVANCED TECHNOLOGY cast steel valve are designed and manufactured to provide maximum service life and dependability. All gate valves are full ported and meet the design requirements of American Petroleum Institute Standard API 600 & API 6D, British Standard BS 1414 & BS EN 1984 and generally conform to American Society of Mechanical Engineers standard ASME B 16.34. Valves are available in a complete range of body/bonnet materials and trims.

Range of Materials

Standard body/bonnet materials include of carbon steel, low and stainless steels. For special applications they can be supplied in other grades or alloy and stainless steel. There's a full range of trim materials to match any service. Optional packing and gasket materials are available for a full range of service conditions.

Available Modifications for ADVANCED TECHNOLOGY Cast Steel Valves

- Trim Changes
- End Connection Modifications
- Packing and gasket Changes
- Operator Mounting
- Handwheel Extensions
- Pressure Equalizing
- By-Pass
- Customer Specified Coatings
- Weld End Bore Changes
- Oxygen & Chlorine Cleaning & Packaging

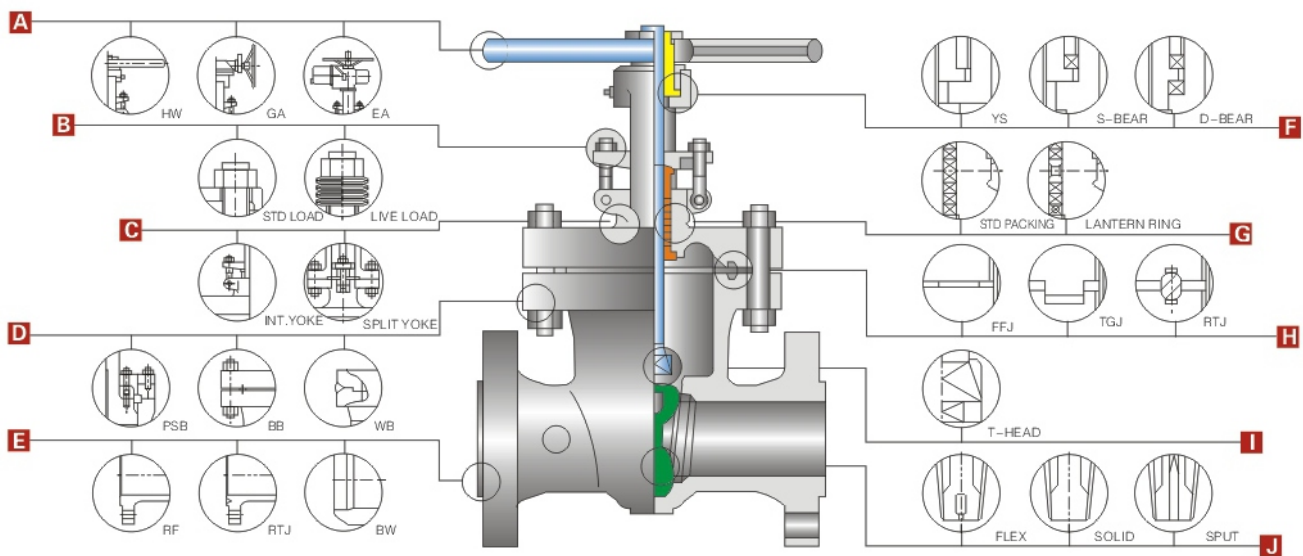

A Operating

Large handwheels for easy operation. Also available with gearing motor actuators, pneumatic or hydraulic actuators for more difficult services.

B Live Load Packing

In services requiring frequent cycling or with high pressure/temperature variations, live loading extends the service life between maintenance periods by requiring less frequent packing gland adjustments. Belleville spring are employed to provide constant packing gland stress.

C OS & Y

Outside Screw and Yoke. Cast steel gate valve yoke integral with bonnet for 150Lb-8', 600Lb-6', 900Lb-4' & Small

D BB

Bolted bonnet. Welding bonnet and pressure seal bonnet in services requiring frequent cycling or with high pressure/temperature variations.

E End Connections

A choice of Flanged, RTJ flanged or Butt welding end for piping flexibility.

F Yokesleeve

Extra long thread engagement between yoke sleeve and stem provide long thread life. Valves of sizes larger than 150Lb-12' 300Lb-10', 600Lb-6' 900Lb/1500Lb/2500Lb-4' are regularly provided with roll bearing yokes.

G Lantern ring and double packing set

Lantern ring with leak-off fitting connection and double packing stack is optionally available for critical services.

H Body-to-Bonnet Joint

A flat face gasket joint is used in the 150Lb valves. A male and female joint is used in 300Lb to 600Lb valves. Ring joint is used in the body to bonnet connection in 900Lb & higher rated valves.

I Stem

All wedge gate valves are provided with upset forged T-head stems. By forging the T-head, the stem at the stem-wedge connection is strengthened. This design also allows the wedge to self-align, eliminating the possibility of a bent stem jamming the wedge.

J Wedge

Integral guide rib faces assure self-centering of wedge. Flexible wedge gate valve has a one-piece, twin-disc wedge, which is designed so that each half flexes independently. Available in solid, flex split and HIS designs.

Applicable Standards

- ★ STEEL GATE VALVES, API608/API6D
- ★ STEEL GATE VALVES, ISO10434/ISO14313
- ★ STEEL VALVES, ASME B16.34
- ★ FACE TO FACE, ASME B16.10
- ★ END FLANGES, ASME B16.5
- ★ BUTTWELDING ENDS, ASME B16.25
- ★ INSPECTION AND TEST API598/API6D

Design Description

- ▲ FULL PORT DESIGN
- ▲ OUTSIDE SCREW AND YOKE
- ▲ BOLTED BONNET
- ▲ FLAXIBLE WEDGE
- ▲ CHOICE OF SOLID OR SPLIT WEDGE
- ▲ RENEWABLE SEAT RINGS
- ▲ FORGED T-THREAD STEM
- ▲ RISING STEM AND NON-RISING HANDWHEEL
- ▲ AVAILABLE WITH GEAR OPERATOR

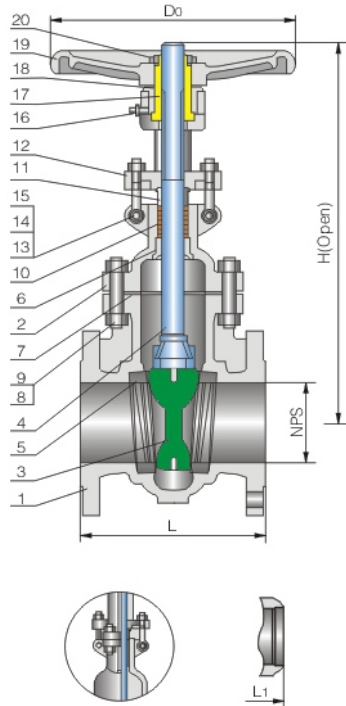

Materials of Parts

No	Part Name	ASTM Material				
		Carbon Steel		Alloy Steel	Stainless Steel	
1	Body	A216-WCB	A352-LCB	A217-WC6	A351-CF8	A351-CF8M
2	Bonnet	A216-WCB	A352-LCB	A217-WC6	A351-CF8	A351-CF8M
3	Wedge	A216-WCB+Cr13	A352-LCB	A217-WC6+HF	A351-CF8	A351-CF8M
4	Stem	A182-F6a	A182-F6a	A182-F11	A276-304	A182-F316
5	Seat ring	A105+CR13	A350-LF2	A182-F11+HF	A351-CF8	A351-CF8M
6	Back seat	A276-420	A276-420	A276-304	A276-304	A182-F316
7	Gasket	Spiral wound (Graphite+304)				
8	Bonnet Stud	A193-B7	A320-L7	A193-B16	A193-B8	A193-B8
9	Bonnet Nut	A182-F6a	A194-4	A194-7	A194-8	A194-8
10	Packing	Graphite				
11	Gland	A182 F6a	A182F6a	A182-F6a	A182-F304	A182-F316
12	Glad Flange	A216-WCB	A216 WCB	A216-WCB	A351-CF8	A351-CF8
13	Eyebolt Pin	Carbon Steel	Carbon Steel	A276-420	A276-304	A276-316
14	Eyebolt	A193 B7	A320 L7	A193-B16	A193-B8	A193-B8
15	Eyebolt Nut	A194-2H	a194-4	A194-7	A194-8	A194-8
16	Grease Fitting	Brass-Brone				
17	Yokesleeve	Aluminium-Bronze				
18	Yokesleeve Jamnut	Carbon Steel				
19	Handwheel	Malleble Iron				
20	Handwheel Nut	Carbon Steel				

Notes: 1) Ductile ni-resist optional
 2) Wedge and seat ring may either be solid facing material or a base material equal to or better than the body/bonnet material with facing as shown.

Dimensions Data ANSI Class 150Lb

NPS	2	2½	3	4	6	8	10	12	14	16	18	20	24	26	28	30	32	36	in
DN	50	65	80	100	150	200	250	300	350	400	450	500	600	650	700	750	800	900	mm
L (RF)	7.00	7.50	8.00	9.00	10.50	11.50	13.00	14.00	15.00	16.00	17.00	18.00	20.00	22.00	24.00	24.00	28.00	28.00	in
L (BW)	8.5	9.5	11.12	12.00	15.88	16.50	18.00	19.75	22.50	24.00	26.00	28.00	32.00	34.00	36.00	36.00	38.00	40.00	in
H (Open)	15.25	17.00	18.88	23.00	30.50	37.62	45.50	53.12	59.38	67.00	74.50	83.50	98.25	110.50	116.50	124.00	129.00	146.50	in
Wt(kg)	18	25	32	50	77	121	178	265	463	463	621	792	1521	1521	1838	2261	2490	3310	RF
	15	18	26	41	69	108	156	248	424	424	587	752	1570	1570	1900	3310	2540	3380	BW

Dimensions Data ANSI Class 300Lb

NPS	2	2½	3	4	6	8	10	12	14	16	18	20	24	26	28	30	32	36	in
DN	50	65	80	100	150	200	250	300	350	400	450	500	600	650	700	750	800	900	mm
L (RF)	8.50	9.50	11.12	12.00	15.88	16.50	18.00	19.75	30.00	33.00	36.00	39.00	45.00	49.00	53.00	55.00	60.00	68.00	in
L (BW)	8.50	9.50	11.12	12.00	15.88	16.50	18.00	19.75	30.00	33.00	36.00	39.00	45.00	49.00	53.00	55.00	60.00	68.00	in
H (Open)	16.12	17.88	20.00	24.00	31.75	39.38	47.62	55.75	62.25	67.88	77.12	86.38	102.00	117.00	122.00	126.00	130.00	152.00	in
Wt(kg)	23	35	50	71	144	209	322	482	683	950	1145	1635	2660	3090	3310	3595	3720	3985	RF
	17	26	39	53	113	164	256	390	565	805	965	1410	2305	2540	2725	3055	3360	3630	BW

Applicable Standards

- ★ STEEL GATE VALVES, API600/API6D
- ★ STEEL GATE VALVES, ISO10434/ISO14313
- ★ STEEL VALVES, ASME B16.34
- ★ FACE TO FACE, ASME B16.10
- ★ END FLANGES, ASME B16.5
- ★ BUTTWELDING ENDS, ASME B16.25
- ★ INSPECTION AND TEST API598/API6D

Design Description

- ▲ FULL PORT DESIGN
- ▲ OS&Y OUTSIDE SCREW AND YOKE
- ▲ BB, BOLTED BONNET
- ▲ FLAXIBLE WEDGE, FULLY GUIDED
- ▲ CHOICE OF SOLID OR SPLIT WEDGE
- ▲ RENEWABLE SEAT RINGS
- ▲ FORGED T-THREAD STEM
- ▲ RISING STEM AND NON-RISING HANDWHEEL
- ▲ FLANGED OR BUTT WELDING ENDS
- ▲ AVAILABLE WITH GEAR OPERATOR

Materials of Parts

No	Part Name	ASTM Material				
		Carbon Steel		Alloy Steel	Stainless Steel	
1	Body	A216-WCB	A352-LCB	A217-WC6	A351-CF8	A351-CF8M
2	Bonnet	A216-WCB	A352-LCB	A217-WC6	A351-CF8	A351-CF8M
3	Wedge	A216-WCB+Cr13	A352-LCB	A217-WC6+HF	A351-CF8	A351-CF8M
4	Stem	A182-F6a	A182-F6a	A182-F11	A276-304	A182-F316
5	Seat ring	A105+Cr13	A350-LF2	A182-F11+HF	A351-CF8	A351-CF8M
6	Stem Back seat	A276-420	A276-420	A276-304	A276-304	A182-316
7	Bonnet Gasket	Spiral wound (Graphite+304)				
8	Bonnet Stud	A193-B7	A320-L7	A193-B16	A193-B8	A193-B8
9	Bonnet Stud Nut	A194-2H	A194-4	A194-7	A194-8	A194-8
10	Packing	Graphite				
11	Gland	A182 F6a	A182F6a	A182-F6a	A182-F304	A182-F316
12	Gland Flange	A216-WCB	A216 WCB	A216-WCB	A351-CF8	A351-CF8
13	Eyebolt Pin	Carbon Steel	Carbon Steel	A276-420	A276-F304	A276-F316
14	Eyebolt	A173 B7	A320 L7	A193-B16	A193-B8	A193-B8
15	Eyebolt Nut	A194-2H	A194-4	A194-7	A194-8	A194-8
16	Grease Fitting	Brass-Brone				
17	Yokesleeve	Aluminium-Bronze				
18	Yokesleeve Jamnut	Carbon Steel				
19	Handwheel	Malleble Iron				
20	Handwheel Nut	Carbon Steel				

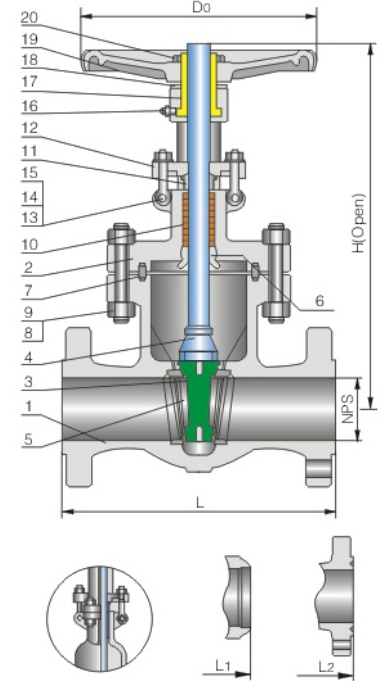

- Notes: 1) Ductile ni-resist optional
 2) Wedge and seat ring may either be solid facing material or a base material equal to or better than the body/bonnet material with facing as shown.

Dimensions Data ANSI Class 600Lb

NPS	2	2½	3	4	6	8	10	12	14	16	18	20	24	26	28	30	32	36	in
DN	50	65	80	100	150	200	250	300	350	400	450	500	600	650	700	750	800	900	mm
L/L1 (RF/BW)	11.50	13.00	14.00	17.00	22.00	26.00	31.00	33.00	35.00	39.00	43.00	47.00	55.00	57.00	61.00	65.00	70.00	82.00	in
	292	330	356	432	559	660	787	838	889	991	1092	1194	1397	1448	1549	1651	1778	2083	mm
L2 (RTJ)	11.62	13.12	14.12	17.12	22.12	26.12	31.12	33.12	35.12	39.12	43.12	47.25	55.38	57.50	61.50	66.50	70.62	82.62	in
	295	333	359	435	562	664	791	841	892	994	1095	1200	1407	1461	1562	1664	1794	2099	mm
H (Open)	16.50	18.75	20.38	25.50	33.00	40.38	48.38	57.00	62.00	70.62	76.00	87.00	101.50	105.00	109.50	114.00	124.00	140.00	in
	418	476	518	646	840	1025	1230	1450	1575	1795	1930	2210	2580	2665	2780	2895	3150	3560	mm
Wt(kg)	36	52	67	112	170	393	610	890	1245	1530	1965	2450	2995	3475	3725	4045	4185	4480	in
	29	42	53	83	125	310	472	730	1055	1240	1625	2030	2590	2855	3065	3440	3780	4085	mm

Dimensions Data ANSI Class 900Lb

NPS	2	2½	3	4	6	8	10	12	14	16	18	20	24	in
DN	50	65	80	100	150	200	250	300	350	400	450	500	600	mm
L1 (RF/BW)	14.50	16.50	15.00	18.00	24.00	29.00	33.00	38.00	40.50	44.50	48.00	52.00	61.00	in
	368	419	381	457	610	737	838	965	1029	1130	1219	1321	1549	mm
L2 (RTJ)	14.62	16.62	15.12	18.12	24.12	29.12	33.12	38.12	40.88	44.88	48.50	52.50	61.75	in
	371	422	384	460	613	741	841	968	1038	1140	1232	1334	1568	mm
H (Open)	19.62	21.50	22.50	26.62	35.50	53.00	53.00	60.00	74.88	81.00	87.00	101.00	104.00	in
	498	547	573	678	900	1103	1345	1525	1900	2055	2215	2565	2640	mm
Wt(kg)	74	131	101	172	335	640	1100	1600	2250	2850	3060	3935	4900	RF/RTJ
	54	105	78	135	260	515	920	1380	2010	2565	3485	3250	4065	BW

Applicable Standards

- ★ STEEL GATE VALVES, API600/API6D
- ★ STEEL GATE VALVES, ISO10434/ISO14313
- ★ STEEL VALVES, ASME B16.34
- ★ FACE TO FACE, ASME B16.10
- ★ END FLANGES, ASME B16.5
- ★ BUTTWELDING ENDS, ASME B16.25
- ★ INSPECTION AND TEST API598/API6D

Design Description

- ▲ FULL PORT DESIGN
- ▲ OUTSIDE SCREW AND YOKE
- ▲ PRESSURE SEAL
- ▲ FLAXIBLE WEDGE FULLY GUIDED
- ▲ CHOICE OF SOLID OR SPLIT WEDGE
- ▲ RENEWABLE SEAT RINGS
- ▲ FORGED T-THREAD STEM
- ▲ RISING STEM AND NON-RISING HANDWHEEL
- ▲ FLANGED OR BUTT WELDING ENDS
- ▲ AVAILABLE WITH GEAR OPERATOR

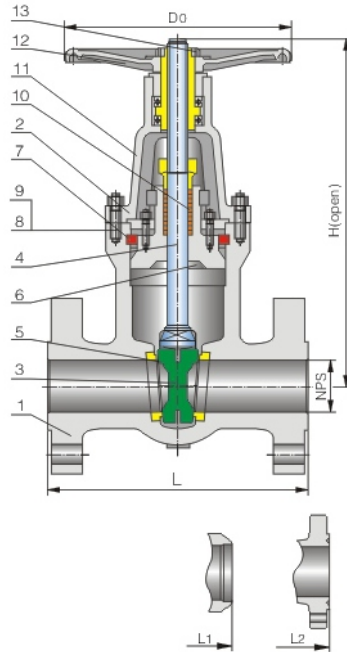

Materials of Parts

No	Part Name	ASTM Material				
		Carbon Steel		1¼Cr-½Mo	Stainless Steel	
1	Body	A216-WCB	A352-LCB	A217-WC6	A351-CF8	A351-CF8M
2	Bonnet	A216-WCB	A352-LCB	A217-WC6	A351-CF8	A351-CF8M
3	Wedge	A216-WCB+Cr13	A352-LCB	A217-WC6+HF	A351-CF8	A351-CF8M
4	Stem	A182-F6a	A182-F6a	A182-F11	A276-304	A182-F316
5	Seat ring	A105+CR13	A350-LF2	A182-F11+HF	A351-CF8	A351-CF8M
6	Back seat	A276-420	A276-420	A276-304	A276-304	A182-F316
7	Gasket	Spiral wound (Graphite+304)				
8	Bonnet Stud	A193-B7	A320-L7	A193-B7	A193-B8	A193-B8
9	Bonnet Nut	A194-2H	A194-4	A194-2H	A194-8	A194-8
10	Packing	Graphite				
11	Gland Flange	A182 F6a	A216 WCB	A216-WCB	A351-CF8	A351-CF8M
12	Handwheel	Malleble Iron				
13	Handwheel Nut	Carbon Steel				

- Notes: 1) Ductile ni-resist optional
 2) Wedge and seat ring may either be solid facing material or a base material equal to or better than the body/bonnet material with facing as shown.

Dimensions Data ANSI Class 900Lb

NPS	2	2½	3	4	6	8	10	12	14	16	18	20	24	in
DN	50	65	80	100	150	200	250	300	350	400	450	500	600	mm
L1/BW	216	254	305	406	559	711	864	991	1067	1194	1346	1473	--	in
L2 (RTJ)	15.50	16.62	18.62	21.62	28.00	33.12	39.38	45.12	50.25	55.38	61.38	66.38	77.62	in
	371	422	473	549	711	841	1000	1146	1276	1407	1559	1686	1972	mm
H (Open)	24.25	26.00	30.00	34.12	39.50	45.00	54.00	61.00	74.88	80.50	93.75	101.50	114.75	in
	615	658	760	868	1005	1145	1370	1550	1900	2050	2380	2580	2915	mm
Wt(kg)	116	166	209	296	510	920	1910	3145	4100	6200	8965	13100	15860	RF
	105	150	188	265	412	760	1640	2755	3200	5300	8070	11790	14275	BW

Dimensions Data ANSI Class 2500Lb

NPS	2	2½	3	4	6	8	10	12	14	16	18	20	24	in
DN	50	65	80	100	150	200	250	300	350	400	450	500	600	mm
L1/BW	279	330	368	457	610	762	914	1041	--	--	--	--	--	in
L2 (RTJ)	17.88	20.50	23.00	26.88	36.50	40.88	50.88	56.88	--	--	--	--	--	in
	454	514	584	683	927	1038	1292	1445	--	--	--	--	--	mm
H (Open)	24.88	29.00	35.00	41.50	57.00	63.38	81.75	89.75	--	--	--	--	--	in
	631	736	890	1055	1450	1610	2075	2280	--	--	--	--	--	mm
Wt(kg)	155	210	310	580	1600	2450	4570	7150	--	--	--	--	--	RF
	124	160	245	460	1310	2010	3800	6000	--	--	--	--	--	BW

Applicable Standards

- ★ STEEL GATE VALVES, API602
- ★ STEEL VALVES, ASME B16.34
- ★ FACE TO FACE MANUFACTURER STANDARD
- ★ FACE TO FACE, FLANGED, ASME B16.10
- ★ END FLANGES, ASME B16.5
- ★ BUTTWELDING ENDS, ASME B16.25
- ★ SOCKET-WELDING ENDS, ASME B16.11
- ★ SCREWED ENDS, ASME B1.20.1
- ★ INSPECTION AND TEST API598

Design Description

- ▲ OUTSIDE SCREW AND YOKE (OS&Y)
- ▲ BOLTED BONNET
- ▲ CHOICE OF WB, WELDING BONNET
- ▲ SINGLE WEDGE
- ▲ RENEWABLE SEAT RINGS
- ▲ RENEWABLE SEAT RINGS
- ▲ YOKE INTEGRAL WITH BONNET
- ▲ RISING STEM AND NON-RISING HANDWHEEL
- ▲ SW, SOCKET-WELDING ENDS
- ▲ SC, SCREWED WENDS
- ▲ BW, BUTTWELDING ENDS
- ▲ FLANGED ENDS

Materials of Parts

No	Part Name	ASTM Material			
		CS	Alloy Steel	Stainless Steel	
1	Body	A105	A182-F11	A182-F304	A182-F316
2	Bonnet	A105	A182-F11	A182-F304	A182-F316
3	Wedge	A182-F6a	A182-F6a+HF	A182-F304	A182-F316
4	Stem	A276-410	A276-410	A276-410	A276-410
5	Seat ring	A276-410	A276-410+HF	A182-F304	A182-F316
6	Gasket	Spiral wound (Graphite+304)		Spiral wound (Graphite+316)	
7	Bonnet Stud	A193-B7	A193-B16	A193-B8	A193-B8
8	Packing	Graphite			
9	Gland	A276-410	A276-410	A276-F304	A276-F316
10	Gland Flange	A105	A105	A182-304	A182-F314
11	Eyebolt Pin	A276-410		A276-F304	A276-F316
12	Eyebolt	A193-B7	A193-B16	A193-B8	A193-B8
13	Eyebolt Nut	A194-2H	A194-7	A194-8	A194-8
14	Yokesleeve	A276-410			
15	Handwheel	Malleble iron			
16	Handwheel Nut	Carbon steel			

Notes: 1) Spiral wound construction.

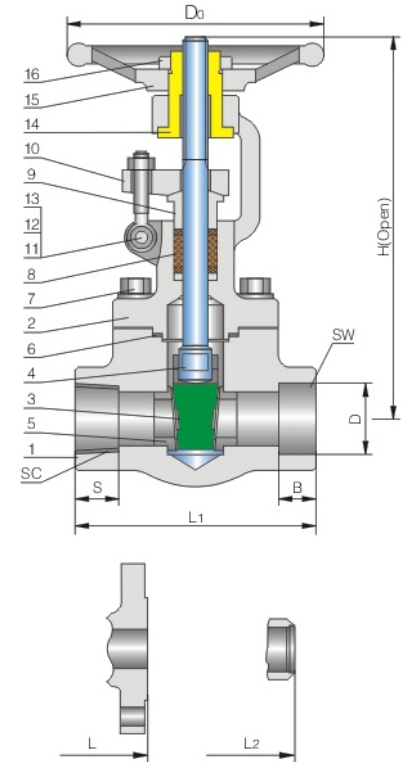

Dimensions Data

NPS DN	Unit	L1 ¹ /L2	L(Flanged Ends)			d	SW		SC		H(Open)	DO	WT ² (Kg)
			150lb	300lb	600lb		D	B	NPT	S			
3/8	in	3.12	4.00	5.50	6.50	0.394	0.693	0.378	3/8	0.540	6.00	4.00	4.5/4
10	mm	79	102	140	165	10	17.6	9.6	3/8	13.6	151	100	
1/2	in	3.12	4.25	5.50	6.50	0.394	0.858	0.378	1/2	0.535	6.00	4.00	5.1/4
15	mm	79	108	140	165	10	21.8	9.6	1/2	13.6	151	100	
3/4	in	3.62	4.62	6.00	7.50	0.531	1.067	0.500	3/4	0.547	6.25	4.00	8.2/4.3
20	mm	92	117	152	190	13.5	27.1	12.7	3/4	13.9	158	100	
1	in	4.38	5.00	6.50	8.50	0.709	1.331	0.500	1	0.681	7.25	5.00	10.5/6.6
25	mm	111	127	165	216	18	33.8	12.7	1	17.3	185	125	
1 1/4	in	4.75	5.50	7.00	9.00	0.945	1.677	0.500	1 1/4	0.709	9.38	6.25	12.4/9.5
32	mm	120	140	178	229	24	42.6	12.7	1 1/4	18	239	160	
1 1/2	in	4.75	6.50	7.50	9.50	1.181	1.917	0.500	1 1/2	0.724	9.50	6.25	20.1/11
40	mm	120	165	190	241	30	48.7	12.7	1 1/2	18.4	243	160	
2	in	5.50	7.00	8.50	11.50	1.437	2.406	0.626	2	0.756	11.00	7.00	28/14.5
50	mm	140	178	216	292	36.5	61.1	15.9	2	19.2	279	180	

Notes: 1) BW, SW or SC.

2) 600lb-RF/800lb-(BW/SW/SC)

Applicable Standards

- ★ STEEL GATE VALVES, API600/API6D
- ★ STEEL GATE VALVES, ISO10434/ISO14313
- ★ STEEL VALVES, ASME B16.34
- ★ FACE TO FACE, ASME B16.10
- ★ END FLANGES, ASME B16.5
- ★ BUTTWELDING ENDS, ASME B16.25
- ★ INSPECTION AND TEST API598/API6D

Design Description

- ▲ PSB PRESSURE SEAL BONNET
- ▲ FLAXIBLE WEDGE FULLY GUIDED
- ▲ CHOICE OF SOLID OR SPLIT WEDGE
- ▲ RENEWABLE SEAT RINGS
- ▲ FORGED T-THREAD STEM
- ▲ RISING STEM AND NON-RISING HANDWHEEL
- ▲ FLANGED OR BUTT WELDING ENDS
- ▲ AVAILABLE WITH GEAR OPERATOR

Materials of Parts

No	Part Name	ASTM Material				
		Carbon Steel		1¼Cr-½Mo	Stainless Steel	
1	Body	A216-WCB	A352-LCB	A217-WC6	A351-CF8	A351-CF8M
2	Yoke	A216-WCB	A352-LCB	A217-WC6	A351-CF8	A351-CF8M
3	Wedge	A216-WCB+Cr13	A352-LCB	A217-WC6+HF	A351-CF8	A351-CF8M
4	Stem	A182-F6a	A182-F6a	A182-F11	A276-304	A182-316
5	Seat ring	A105+HF	A350-LF2	A182-F11+HF	A240-304+FL	A240-316+HF
6	Bonnet	A216-WCB	A352-LCB	A217-WC6	A351-CF8	A351-cf8m
7	Bonnet Gasket	Spiral wound (Graphite+304)		Spiral wound (Graphite+316)		
8	Adaptor	Carbon Steel		A276-304	A276-304	A276-316
9	Retainer Ring	Carbon Steel		A182-F11	A276-304	A276-316
10	Yoke Cap	Carbon Steel			Stainless Steel	
11	Bonnet Stud	A193-B7	A320-L7	A193-B16	A193-B8	A193-B8
12	Bonnet Nut	A194-2H	A194-4	A197-7	A194-8	A194-8
13	Packing	Graphite				
14	Gland	A182 F6a	A182F6a	182-F6a	A182-F304	A182-F316
15	Gland Flange	A216-WCB	A216 WCB	A216-WCB	A351-CF8	A351-CF8
16	Eyebolt Pin	Carbon Steel	Carbon Steel	A276-420	A276-304	A276-316
17	Eyebolt	A193-B7	A320-L7	A193-B16	A193-B8	A193-B8
18	Eyebolt Nut	A194-2H	A194-4	A194-7	A194-8	A194-8
19	Grease Fitting	Brass-Brone				
20	Yokesleeve	Aluminium-Bronze				
21	Yokesleeve Jam Nut	Carbon Steel				
22	Handwheel	Malleble Iron				
23	Handwheel Nut	Carbon Steel				

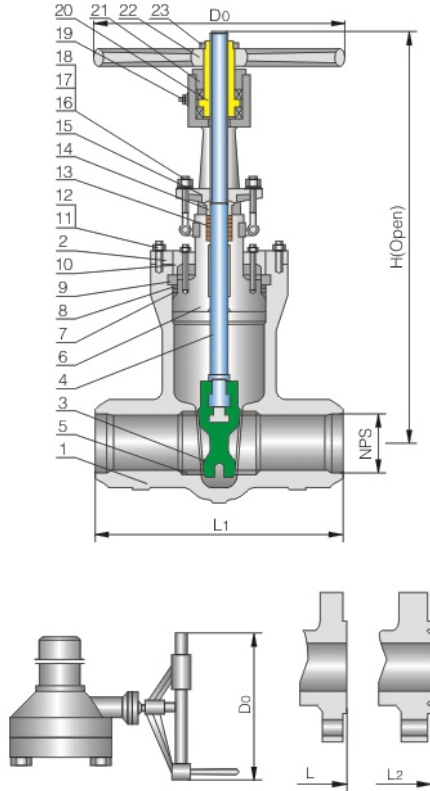

- Notes: 1) Graphite Optional.
 2) Ductile Ni-resist optional
 3) Wedge and seat ring may either be solid facing material or a base material equal to or better than the body/bonnet material with facing as shown.

Dimensions Data ANSI Class 900Lb

NPS	2	2½	3	4	6	8	10	12	14	16	in
DN	50	65	80	100	150	200	250	300	350	400	mm
L1 (BW)	8.50	10.00	12.00	14.00	20.00	26.00	31.00	36.00	39.00	43.00	in
	216	254	305	356	508	660	787	914	991	1092	mm
L (RF)	14.50	165.50	15.00	18.00	24.00	29.00	33.00	38.00	40.50	44.50	in
	368	419	381	457	610	737	838	965	1029	1130	mm
L2 (RTJ)	14.62	16.62	15.12	18.12	24.12	29.12	33.12	38.12	40.88	44.88	in
	371	422	384	460	613	740	841	968	1038	1140	mm
H (Open)	17.62	17.62	19.5	22.88	32.62	37.59	45.5	53.12	59	70.5	in
	448	448	495	580	830	955	1165	1350	1500	1790	mm
Do	14	14	14	14	18	24	28	34	34	34	in
	350	350	350	350	450	600	700	850	850	850	mm
Wt(kg)	39	39	48	69	158	289	482	710	998	1390	BW
	69	69	72	110	253	430	710	1025	1452	1960	RF/RTJ

Applicable Standards

- ★ STEEL GATE VALVES, API600/API6D
- ★ STEEL GATE VALVES, ISO10434/ISO14313
- ★ STEEL VALVES, ASME B16.34
- ★ FACE TO FACE, ASME B16.10
- ★ END FLANGES, ASME B16.5
- ★ BUTTWELDING ENDS, ASME B16.25
- ★ INSPECTION AND TEST API598/API6D

Design Description

- ▲ PSB PRESSURE SEAL BONNET
- ▲ FLAXIBLE WEDGE FULLY GUIDED
- ▲ CHOICE OF SOLID OR SPLIT WEDGE
- ▲ RENEWABLE SEAT RINGS
- ▲ FORGED T-THREAD STEM
- ▲ RISING STEM AND NON-RISING HANDWHEEL
- ▲ FLANGED OR BUTT WELDING ENDS
- ▲ AVAILABLE WITH GEAR OPERATOR

Materials of Parts

No	Part Name	ASTM Material				
		Carbon Steel		1¼Cr-½Mo	Stainless Steel	
1	Body	A216-WCB	A352-LCB	A217-WC6	A351-CF8	A351-CF8M
2	Yoke	A216-WCB	A352-LCB	A217-WC6	A351-CF8	A351-CF8M
3	Wedge	A216-WCB+Cr13	A352-LCB	A217-WC6+HF	A351-CF8	A351-CF8M
4	Stem	A182-F6a	A182-F6a	A182-F11	A276-304	A182-F316
5	Seat ring	A105+HF	A350-LF2	A182-F11+HF	A240-304+FL	A240-316+FL
6	Bonnet	A216-WCB	A352-LCB	A217-WC6	A351-CF8	A351-CF8m
7	Bonnet Gasket	Spiral wound (Graphite+304)				
8	Adaptor	Carbon Steel		A276-304	A276-304	A276-316
9	Retainer Ring	Carbon Steel		A182-F11	A276-304	A276-316
10	Yoke Cap	Carbon Steel			Stainless Steel	
11	Bonnet Stud	A193-B7	A320-L7	A193-B16	A193-B8	A193-B8
12	Bonnet Nut	A194-2H	A194-4	A197-7	A194-8	A194-8
13	Packing	Graphite				
14	Gland	A182 F6a	A182F6a	182-F6a	A182-F304	A182-F316
15	Gland Flange	A216-WCB	A216 WCB	A216-WCB	A351-CF8	A351-CF8
16	Eyebolt Pin	Carbon Steel	Carbon Steel	A276-420	A276-304	A276-316
17	Eyebolt	A193 B7	A320 I7	A193-B16	A193-B8	A193-B8
18	Eyebolt Nut	A194-2H	A194-4	A194-7	A194-8	A194-8
19	Grease Fitting	Brass-Brone				
20	Yokesleeve	Aluminium-Bronze				
21	Yokesleeve Jam Nut	Carbon Steel				
22	Handwheel	Malleble Iron				
23	Handwheel Nut	Carbon Steel				

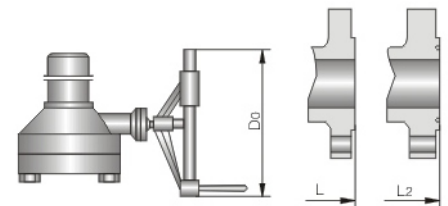
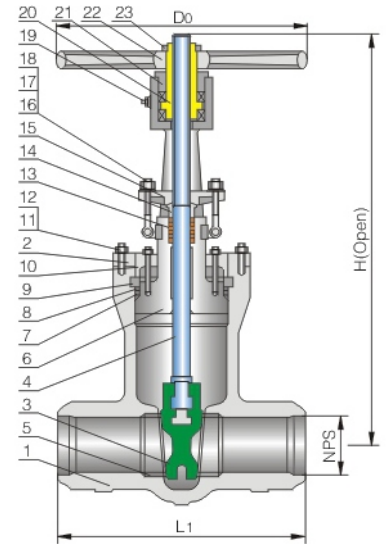

- Notes: 1) Graphite Optional.
 2) Ductile Ni-resist optional
 3) Wedge and seat ring may either be solid facing material or a base material equal to or better than the body/bonnet material with facing as shown.

Dimensions Data ANSI Class 1500Lb ANSI Class 2500Lb

	ANSI Class 1500Lb										ANSI Class 2500Lb										in
	NPS 2	2½	3	4	6	8	10	12	14	16	2	2½	3	4	6	8	10	12	14	16	
L ₁ (BW)	8.50	10.00	12.00	16.00	22.00	28.00	34.00	39.00	42.00	47.00	11.00	13.00	14.50	18.00	24.00	30.00	36.00	41.00	--	--	in
L (RF)	14.50	165.50	18.50	21.50	27.75	32.75	39.00	44.50	49.50	54.48	17.75	20.00	22.75	26.50	36.00	40.25	50.00	56.00	--	--	in
L ₂ (RTJ)	15.50	16.62	18.62	21.62	28.00	33.12	39.38	45.12	50.25	55.38	17.88	20.50	23.00	26.88	36.50	40.88	50.88	56.88	--	--	in
H (Open)	17.62	17.62	21.62	25.25	33.5	38.62	46.5	62.25	70.5	78	22.5	22.5	25.62	30	36.62	41.38	44.88	60.25	--	--	in
D1	14	14	14	18	24	28	34	34	34	34	14	14	18	24	28	34	34	34	--	--	in
Wt(kg)	45	45	55	77	175	323	540	795	1115	1556	110	110	150	175	380	575	980	1570	--	--	BW
	80	80	95	123	283	481	795	1148	1626	2195	165	195	235	316	635	910	1780	2680	--	--	RF/RTJ

Applicable Standards

- ★ STEEL GATE VALVES, API600/API6D
- ★ STEEL GATE VALVES, ISO10434/ISO14313
- ★ STEEL VALVES, ASME B16.34
- ★ FACE TO FACE, ASME B16.10
- ★ END FLANGES, ASME B16.5
- ★ BUTTWELDING ENDS, ASME B16.25
- ★ INSPECTION AND TEST API598/API6D

Design Description

- ▲ FULL PORT DESIGN
- ▲ OS & Y, OUTSIDE SCREW AND YOKE
- ▲ BB, BOLTED BONNET
- ▲ FLAXIBLE WEDGE
- ▲ CHOICE OF SOLID OR SPLIT WEDGE
- ▲ RENEWABLE SEAT RINGS
- ▲ FORGED T-THREAD STEM
- ▲ RISING STEM AND NON-RISING HANDWHEEL
- ▲ FLANGED OR BUTT WELDING ENDS
- ▲ AVAILABLE WITH BG OPERATOR

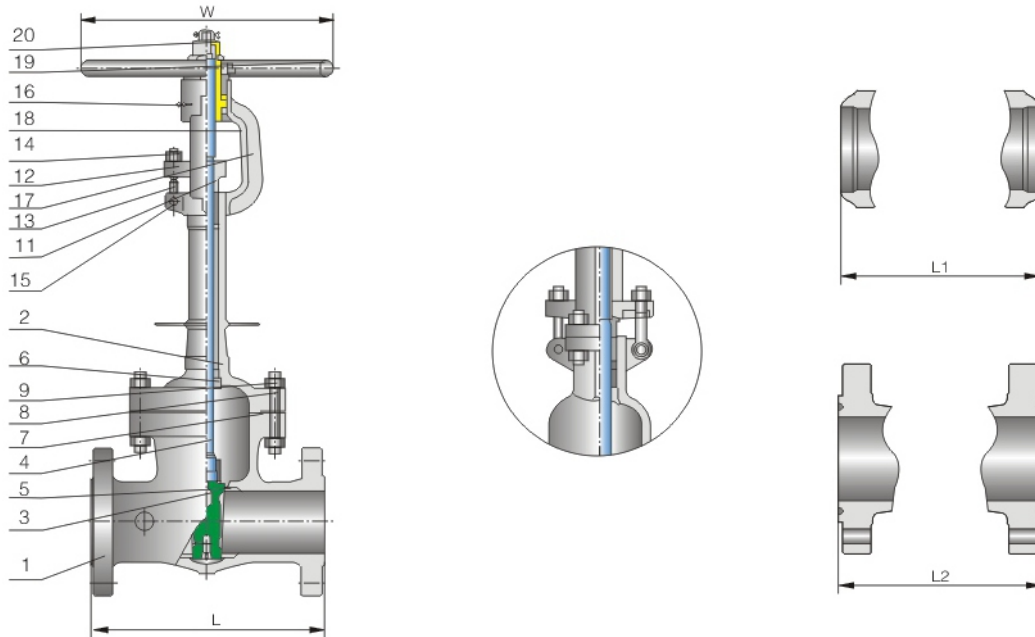

Standard Material Specifications

No	Part Name	ASTM Material								
		Carbon Steel	2.5Ni	3.5Ni	304 Type	316 Type	304L Type	316L Type	20 Alloy	
1	Body	A352 LCB	A352 LC2	A352 LC3	A351 CF8	A351 CF8M	A351 CF3	A351 CF3M	A351 CN7M	
2	Bonnet	A352 LCB	A352 LC2	A352 LC3	A351 CF8	A351 CF8M	A351 CF3	A351 CF3M	A351 CF7M	
3	Wedge	LCB+304*1	LCB+304*1	LCB+304*1	A351 CF8	A351 CF8M	A351 CF3	A351 CF3M	A351 CF7M	
4	Stem	A182 F304	A182 F304	A182 F304	A182 F304	A182 F316	A182 F304L	A182 F316L	20-Alloy	
5	Seat Ring	A182+F304*1	A182+F304*1	A182+F304*1	NA				NA	
6	Back Seat	A276 304	A276 304	A276 304	NA				NA	
7A	Bonnet Gasket	304+graphite	304+graphite	304+graphite	304+graphite	316+graphite	304L+graphite	316L+graphite	316+graphite	
7B	Ring Gasket	A182 F304	A182 F304	A182 F304	A182 F304	A182 F316	A182 F304L	A182 F316L	20-Alloy	
8	Bonnet Bolt	A320 L7	A320 L7	A320 L7	A193 B8	A193 B8M	A193 B8	A193 B8M	A193 B8M	
9	Bonnet Nut	A194 4	A194 4	A194 4	A194 8	A194 8M	A194 8	A194 8M	A194 8M	
10	Packing	Graphite	Graphite	Graphite	Graphite *2	Graphite *2	Graphite *2	Graphite *2	Graphite *2	
11	Gland	A276 410	A276 410	A276 410	A276 304	A276 316	A276 304L	A276 316L	20-Alloy	
12	Gland Flange	A352 LC2	A352 LCB	A352 LC3	A351 CF8	A351 CF8	A351 CF8	A351 CF8	A351 CF8	
13	Eyebolt	A320 L7	A320 L7	A320 L7	A193 B8	A193 B8	A193 B8	A193 B8	A193 B8	
14	Eyebolt Nut	A194 4	A194 4	A194 4	A194 8	A194 8	A194 8	A194 8	A194 8	
15	Eyebolt Pin	A276 410	A276 410	A276 410	A276 304	A276 304	A276 304	A276 304	A276 304	
16	Greas Fitting	Commercial	Commercial	Commercial	Commercial				Commercial	
17	Stem Nut	Bronze	Bronze	Bronze	Bronze				Bronze	
18	Jam Nut	Carbon steel	Carbon Steel	Carbon Steel	Carbon Steel				Stainless steel	
19	Hand Wheel	Malleble iron	Malleble iron	Malleble iron	Malleble iron				Malleble iron	
20	Wheel Nut	Carbon Steel	Carbon Steel	Carbon Steel	Carbon Steel				Carbon Steel+Zn	
*1	PN>600 CLASS seal face will be HF									
*2	PTFE Optional									
*3	Ductile Ni-Resist iron Optional									
NA	Integral with vessell									

Dimensions Data ANSI Class 150

NPS	in	2	3	4	6	8	10	12	14	16	18	20	24	28	30	36	40	42	48	52		
DN	mm	50	65	80	100	150	200	250	300	350	400	450	500	600	700	750	900	1000	1050	1200	1300	
L	in	7.0	7.5	8.0	9.0	10.5	11.5	13.0	14.0	15.0	16.0	17.0	18.0	20.0	24.0	24.0	28.0	30.0	31.0	34.0	36.0	
	mm	178	190	203	229	267	292	330	356	381	406	432	457	508	610	610	711	762	813	864	914	
L1	in	8.5	9.5	11.12	12.0	15.87	16.5	18.0	19.75	22.5	24.0	26.0	28.0	32.0	36.0	36.0	40.0	42.0	43.0	46.0	54	
	mm	216	241	282	305	403	419	457	502	572	610	660	711	813	914	914	1016	1067	1092	1168	1372	
H	in	15.4	16.7	18.1	22.8	30.6	38.4	46.4	54.6	60.0	68.7	79.1	91.7	109.6	127.4	134.5	161.8	183.9	174.4	217.5	227	
	mm	390	425	461	580	776	976	1178	1387	1523	1745	2010	2330	2748	3236	3417	4109	4670	4430	5525	5766	
W	in	7.9	7.9	7.9	9.8	11.8	14.0	17.7	17.7	19.7	22.0	13.8	17.7	17.7	22.0	22.0	27.9	31.5	31.5	35.4	35.4	
	mm	200	200	200	250	300	355	450	450	500	560	350	450	450	560	560	710	800	800	900	900	
Wt (Kg)	RF	IB	48.5	55.1	66.2	99.2	187	295.5	445	639	816	1177	1475	1786	3153	4558	4827	7856	10370	10143	15677	18742
		KG	22	25	30	45	85	134	202	290	370	534	669	810	1430	2067	2189	3563	4703	4600	7110	8500
	BW	IB	44.1	46.3	61.7	92.6	161	244	399	584	750	1111	1365	1697	3336	4756	4981	8011	10436	10198	15545	18853
		KG	20	21	28	42	73	111	181	265	340	504	619	770	1513	2157	2259	3633	4733	4625	7050	8550

Dimensions Data ANSI Class 300

NPS	in	2	2½	3	4	6	8	10	12	14	16	18	20	24	28	30	36	40	42	48	
	mm	50	65	80	100	150	200	250	300	350	400	450	500	600	700	750	900	1000	1050	1200	
L & L1	in	8.5	9.5	11.2	12.0	15.88	16.5	18.0	19.75	30.0	33.0	36.0	39.0	45.0	53.0	55.0	68.0	76.0	78.0	87.2	
	mm	216	241	282	305	403	419	457	502	762	838	914	991	1143	1346	1397	1727	1930	1981	2215	
L2	in	9.12	10.12	11.75	12.62	16.5	17.12	18.62	20.37	30.62	33.62	36.62	39.75	45.88	54.0	56.0	69.12	--	--	--	
	mm	232	257	298	321	419	435	473	518	778	854	930	1010	1165	1372	1422	1756	--	--	--	
H	in	16.2	17.7	19.0	23.7	32.0	40.2	48.8	56.8	66.1	78.4	85.9	93.5	112.6	130.0	148.5	169.8	188.6	198.1	217.4	
	mm	412	450	483	601	813	1020	1239	1443	1679	1993	2181	2376	2860	3302	3772	4312	4791	5032	5522	
W	in	7.9	7.9	8.8	9.8	14.0	15.7	17.7	19.7	17.7	17.7	22.0	22.0	27.9	35.4	35.4	--	--	--	--	
	mm	200	200	224	250	355	400	450	500	450	450	560	560	710	900	900	--	--	--	--	
Wt (Kg)	RF	lb	63.9	88.2	105.8	163.2	313.1	485.1	721.0	1094	1530	2170	2880	3409	5204	8052	9591.6	15104.6	18654.3	20947.5	27342
		Kg	29	40	48	74	142	220	327	496	694	984	1306	1546	2360	3660	4350	6850	8460	9500	12400
	BW	lb	52.9	77.2	81.6	141.1	269.0	379.2	510.4	862	1420	1839	2317	2703	4212	6637	7629.3	11003	13582.6	14994	19845
		Kg	24	35	37	64	122	172	232	391	644	834	1051	1226	1910	3010	3460	4990	6160	6800	9000

Dimensions Data ANSI Class 600

NPS	in	2	2½	3	4	6	8	10	12	14	16	18	20	24	28	30	36	40	42	
	mm	50	65	80	100	150	200	250	300	350	400	450	500	600	700	750	900	1000	1050	
L & L1	in	11.5	13.0	14.0	17.0	22.0	26.0	31.0	33.0	35.0	39.0	43.0	47.0	55.0	61.0	65.0	82.0	94.0	98.0	
	mm	292	330	356	432	556	660	787	838	889	991	1092	1194	1397	1594	1651	2083	2387	2489	
L2	in	11.62	13.12	14.12	17.12	22.12	26.12	31.12	33.12	35.12	39.12	43.12	47.25	55.38	61.5	65.5	82.62	--	--	
	mm	295	333	359	435	562	664	791	841	892	994	1095	1200	1406	1562	1663	2098	--	--	
H	in	18.5	19.5	22.1	26.7	37.2	43.7	52.1	65.9	72.1	82.9	98.0	104.8	116.9	140.2	152.8	179.5	207.6	240.0	
	mm	471	495	561	677	944	1110	1323	1675	1832	2106	2489	2662	2970	3562	3880	4560	5273	6098	
W	in	8.8	8.8	9.8	11.8	17.7	19.7	24.8	22.0	22.0	27.9	27.9	31.5	35.4	--	--	--	--	--	
	mm	224	224	250	300	450	500	630	560	560	710	710	800	900	--	--	--	--	--	
Wt (Kg)	RF	lb	94.3	132.3	154.4	295.5	628	988	1499	2355	2836	4059	5700	6853	10337	13340.6	15313.7	21476.7	23262.8	24144.8
		kg	43	60	70	134	285	448	680	1068	1286	1841	2585	3108	4688	6050	6945	9740	10550	10950
	BW	lb	61.7	99.2	132.3	229.3	452	690	1180	2145	2571	3332	4741	5640	8595	10980.9	12590.0	17948.7	18830.7	19337.9
		kg	28	45	60	104	205	313	535	973	1166	1511	2150	2558	3898	4980	5710	8140	8540	8770

- Globe Valve**
- Cast Steel Globe Valve**
- Forged Steel Globe Valve**
- Pressure Seal, Cast Steel Globe Valve**
- Cryogenic Globe Valve**

Globe Valve

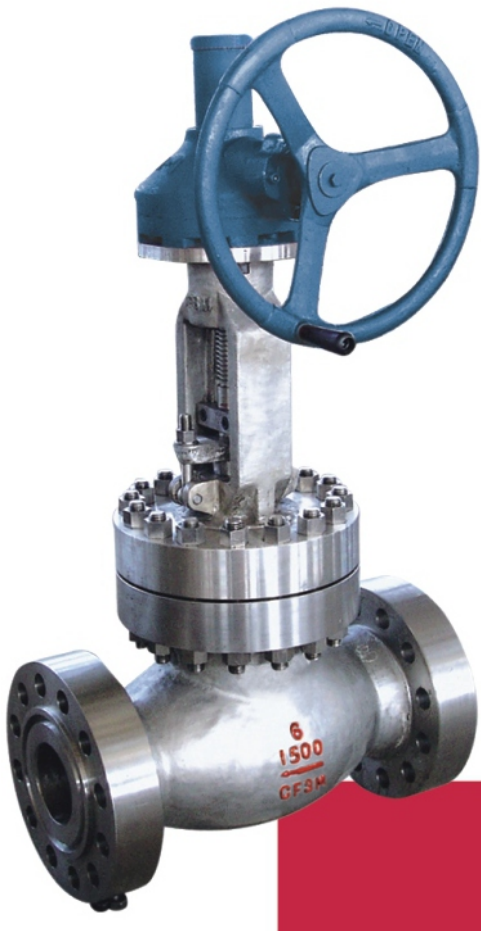

The open-close member of the globe valve is a cork-like disc, with the sealing face presented as a plane or a conical face, and the disc does a linear movement along with the fluid central line. It is the broadest used valve and the reason for it to be favored comes at its small frictional force between the sealing faces during open and close, being more durable, not high opening, easy manufacture and repair, and being suitable for not only middle and low pressures but also high one. In the recent years since the sealed valve comes into being, the medium in a globe valve is changed to flow into the valve cavity from the upper of the disc and, under the medium pressure at this time, the force to close the valve becomes small while the one to open it becomes large, getting the stem diameter relatively reduced. Meanwhile, under the medium action, this type of valve is made more tight and is applicable for the pipeline of petroleum, chemical industry and electric power system.

Design

ADVANCED TECHNOLOGY cast steel globe valves are designed and manufactured to provide maximum service life and dependability. All globe valves are full ported and meet the design requirements of BS 1873. BS EN 13709 and generally conform to American Society of Mechanical Engineers standard ASME B16.34. Valves are available in a complete range of body/bonnet material and trims.

Rang of Materials

Standard body/bonnet materials include carbon steel, low alloy and stainless steels. For special applications they can be supplied in other grades of alloy and stainless steel. There's a full range of trim materials to match any service. Optional packing and gasket materials are available for a full range of service conditions.

Available Modifications for ADVANCED TECHNOLOGY Cast Steel Valves

- Trim Changes
- End Connection Modifications
- Packing and Gasket Changes
- Operator Mounting
- Handwheel Extensions
- Pressure Equalizing
- By-pass
- Customer Specified Coatings
- Weld End Bore Changes
- Oxygen & Chlorine Cleaning & Packaging

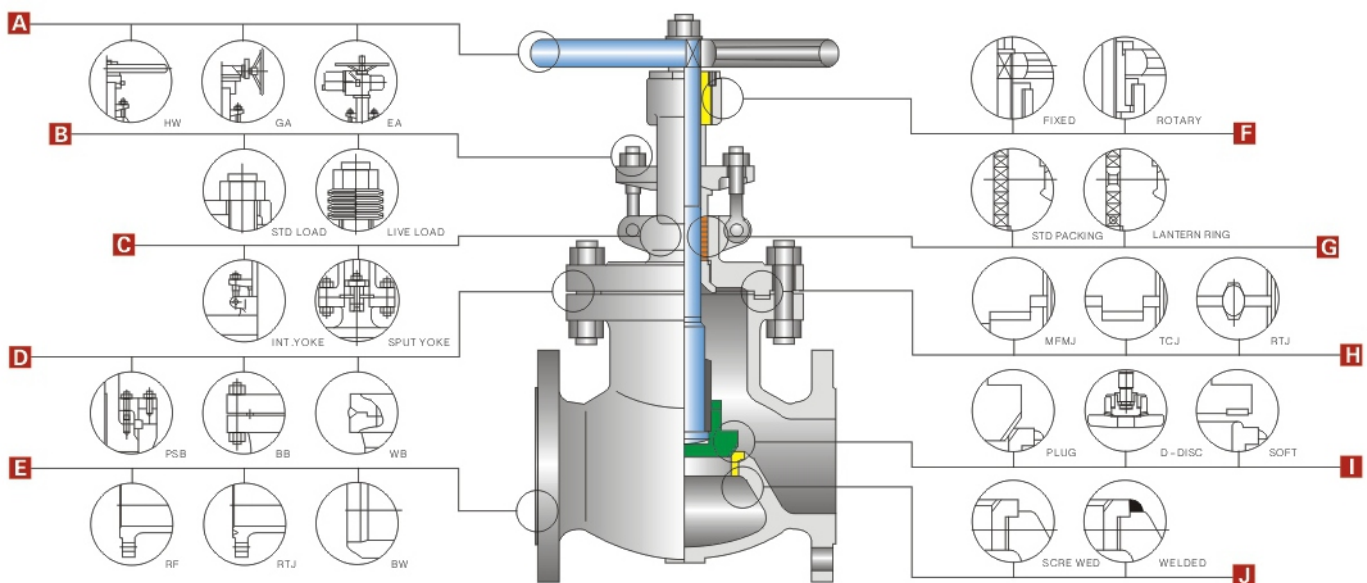

A Operating

Large handwheels for easy operation. Also available with gear, motor actuators, pneumatic or hydraulic actuators for more difficult services.

B Live Load Packing

In services requiring frequent cycling or with high pressure / temperature variations, live loading extends the service life between maintenance periods packing gland adjustments. Belleville springs are employed to provide constant packing gland stress.

C OS & Y

Outside Screw and Yoke. Cast steel globe valve yoke integral with bonnet for 10& smaller.

D BB

Bolted bonnet. Welding bonnet and pressure seal bonnet in services requiring frequent cycling or with high pressure/temperature variations.

E End Connections

A choice of Flanged, RTJ flanged or Butt welding end for piping flexibility.

F Yokesleeve

Furnished in aluminum bronze to reduce operating torque. Most sizes furnished with ball bearing yoke sleeves.

G Lantern ring and double packing set

Lantern ring with leak-off fitting connection and double packing stack is optionally available for critical services.

H Body-to-Bonnet Joint

A Male and Female joint or Tongue and Groove joint is used 150Lb to 600Lb valves, Ring joint is used in the body to bonnet connection in 900Lb & higher rated valves.

I Disc

Plug disc is stem guided on all sizes. Disc has a differential angle front the seat to provide a line contact for maximum sealing. The bottom of V-port disc is fuided by the body seat ring for maximum disc stability in throttling applications. The soft teflon ring is excellent for lower temperature service where tight shut off is required.

J Seat Rings

Separate heavy duty. full ported rings for easy maintenance. Screwed or welded connection into body.

Applicable Standards

- ★ STEEL GLOBE VALVES, BS EN 13709, BS 1873
- ★ STEEL VALVES, ASME B16.34
- ★ FACE TO FACE, ASME B16.10
- ★ END FLANGES, ASME B16.5
- ★ BUTTWELDING ENDS, ASME B16.25
- ★ INSPECTION AND TEST API598

Design Description

- ▲ STRAIGHT PATTERN BODY DESIGN
- ▲ OS & Y, OUTSIDE SCREW AND YOKE
- ▲ BB, BOLTED BONNET
- ▲ YOKE INTEGRAL WITH BONNET
- ▲ RISING STEM AND HANDWHEEL
- ▲ LOOSE DISC, CHOICE OF PLUG OR BALL
- ▲ RENEWABLE SEAT RING
- ▲ IMPACT HANDWHEEL FOR 10' & ABOVE
- ▲ HORIZONTAL SERVICE
- ▲ FLANGED OR BUTTWELDING ENDS
- ▲ AVAILABLE WITH GEAR OPERATOR

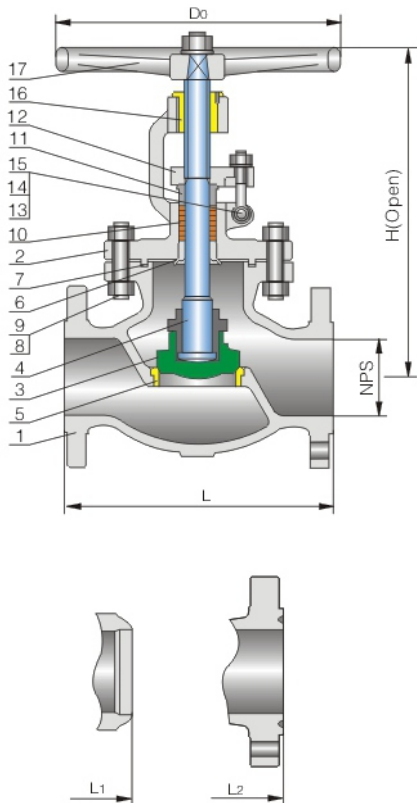

Materials of Parts

No	Part Name	ASTM Material				
		Carbon Steel		Alloy Steel	Stainless Steel	
1	Body	A216-WCB	A352-LCB	A217-WC6	A351-CF8	A351-CF8M
2	Bonnet	A216-WCB	A352-LCB	A217-WC6	A351-CF8	A351-CF8M
3	Disk	A105+Cr13	350-LF2	A182-F11+HF	A351-CF8	A351-CF8M
4	Stem	A182-F6a	A182-F6a	A182-F11	A276-304	A182-F316
5	Seat Ring	A105+Cr13	A350-LF2	A182-F11+HF	A351-CF8	A351CF8M
6	Backseat	A276-420	A276-420	A276-304	A276-304	A182-F316
7	Gasket	Spiral wound (Graphite+304)				
8	Bonnet Stud	A193-B7	A320-L7	A193-B16	A193-B8	A193-B8
9	Bonnet Nut	A194-2H	A194-4	A194-7	A194-8	A194-8
10	Packing	Graphite				
11	Gland	A182 F6a	A182F6a	A182-F6a	A182-F304	A182-F316
12	Gland Flange	A216-WCB	A216-WCB	A216-WCB	A351-CF8	A351-CF8
13	Eyebolt Pin	Carbon Steel	Carbon Steel	A276-420	A276-304	A276-316
14	Eyebolt	A193-B7	A320-L7	A193-B16	A193-B8	A193-B8
15	Eyebolt Nut	A194-2H	A194-4	A194-7	A194-8	A194-8
16	Yokesleeve	Aluminium-Bronze				
17	Handwheel	Malleble Iron				

- Notes: 1) Ductile Ni-resist Optional.
 2) Disc and seat ring may either be solid facing material or a material equal to or better than the body/bonnet material with facing as shown.
 3) Sealing material according to client's demand.

Dimensions Data ANSI Class 150Lb ANSI Class 300Lb

NPS	DN	L/L1 (RF/BW)		L2 (RTJ)	H (Open)		Do		WT(kg)		L/L1 (RF/BW)		L2 (RTJ)	H (Open)		Do		WT(kg)			
		in	mm		in	mm	in	mm	in	mm	in	mm		in	mm	in	mm	in	mm	in	mm
2	50	8.00	203	216	15.00	380	7	180	18	14	10.50	267	11.12	282	16.75	425	8	200	25	20	
2½	65	8.50	216	229	21.00	535	10	240	30	22	11.50	292	12.12	308	19.00	485	10	240	32	22	
3	80	9.50	241	254	17.50	445	11	280	41	33	12.50	318	13.12	333	19.88	505	11	280	38	27	
4	100	11.50	292	305	20.25	515	11	280	64	43	14.00	356	14.62	371	22.50	570	13	320	56	41	
6	150	16.00	406	419	22.00	560	13	320	86	72	17.50	444	18.12	460	25.25	640	16	400	96	75	
8	200	19.50	495	508	24.25	615	13	320	110	88	22.00	559	22.62	575	33.25	845	18	450	150	117	
10	250	24.50	622	635	32.00	815	16	400	280	245	24.50	622	25.12	638	35.50	900	20	500	360	310	
12	300	27.50	698	711	35.88	910	18	450	380	345	28.00	711	28.62	727	38.62	980	24	600	550	492	
14	350	31.00	787	800	48.38	1230	20	500	510	450	--	--	--	--	--	--	--	--	--	--	
16	400	36.00	914	927	57.00	1450	24	600	740	665	--	--	--	--	--	--	--	--	--	--	
in	mm	in	mm	in	mm	in	mm	in	mm	RF/RTJ	BW	in	mm	in	mm	in	mm	in	mm	RF/RTJ	BW

Applicable Standards

- ★ STEEL GLOBE VALVES, BS EN 13709, BS 1873
- ★ STEEL VALVES, ASME B16.34
- ★ FACE TO FACE, ASME B16.10
- ★ END FLANGES, ASME B16.5
- ★ BUTTWELDING ENDS, ASME B16.25
- ★ INSPECTION AND TEST API598

Design Description

- ▲ STRAIGHT PATTERN BODY DESIGN
- ▲ OS & Y, OUTSIDE SCREW AND YOKE
- ▲ BB, BOLTED BONNET
- ▲ YOKE INTEGRAL WITH BONNET
- ▲ RISING STEM AND HANDWHEEL
- ▲ LOOSE DISC, CHOICE OF PLUG OR BALL
- ▲ RENEWABLE SEAT RING
- ▲ IMPACT HANDWHEEL FOR 10' & ABOVE
- ▲ HORIZONTAL SERVICE
- ▲ FLANGED OR BUTTWELDING ENDS
- ▲ AVAILABLE WITH GEAR OPERATOR

Materials of Parts

No	Part Name	ASTM Material				
		Carbon Steel		Alloy Steel	Stainless Steel	
1	Body	A216-WCB	A352-LCB	A217-WC6	A351-CF8	A351-CF8M
2	Bonnet	A216-WCB	A352-LCB	A217-WC6	A351-CF8	A351-CF8M
3	Disk	A216+Cr13	A350-LF2	A182-F11+HF	A351-CF8	A351-CF8M
4	Stem	A182-F6a	A182-F6a	A182-F11	A276-304	A182-F316
5	Seat Ring	A105+Cr13	A350-LF2	A182-F11+HF	A351-CF8	A351CF8M
6	Backseat	A276-420	A276-420	A276-304	A276-304	A182-F316
7	Gasket	Spiral wound (Graphite+304)				
8	Bonnet Stud	A193-B7	A320-L7	A193-B16	A193-B8	A193-B8
9	Bonnet Nut	A194-2H	A194-4	A194-7	A194-8	A194-8
10	Packing	Graphite				
11	Gland	A182 F6a	A182F6a	182-F6a	A182-F304	A182-F316
12	Gland Flange	A216-WCB	A216-WCB	A216-WCB	A351-CF8	A351-CF8
13	Eyebolt Pin	Carbon Steel	Carbon Steel	A276-420	A276-304	A276-316
14	Eyebolt	A193-B7	A320-L7	A193-B16	A193-B8	A193-B8
15	Eyebolt Nut	A194-2H	A194-4	A194-7	A194-8	A194-8
16	Yokesleeve	Aluminium-Bronze				
17	Handwheel	Malleble Iron				

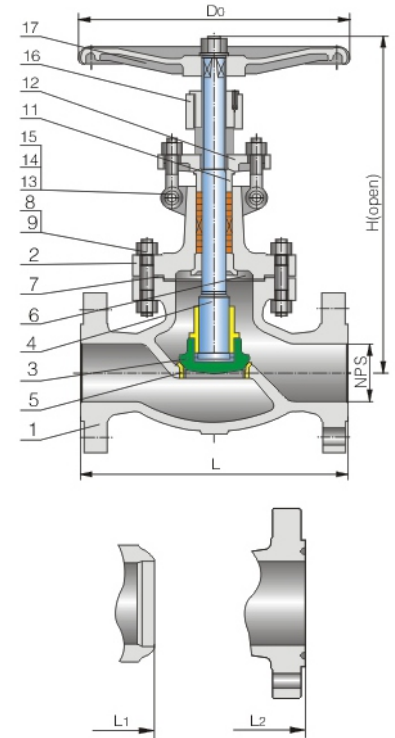

- Notes: 1) Ductile Ni-resist Optional.
 2) Disc and seat ring may either be solid facing material or a base material equal to or better than the body/bonnet material with facing base as shown.
 3) Sealing material according to client's demand.

Dimensions Data ANSI Class 600Lb

ANSI Class 900Lb

NPS		DN		L/L1 (RF/BW)		L2 (RTJ)		H (Open)		Do		WT(kg)		L/L1 (RF/BW)		L2 (RTJ)		H (Open)		Do		WT(kg)	
2	50	11.50	292	11.62	295	17.50	445	10	240	35	27	14.50	368	14.62	371	22.00	560	11	280	57	41		
2½	65	13.00	330	13.12	333	19.75	502	11	280	50	34	16.50	419	16.62	422	23.25	590	13	320	82	53		
3	80	14.00	356	14.12	359	21.00	533	13	320	60	42	15.00	381	15.12	384	25.25	640	16	400	91	58		
4	100	17.00	432	17.12	435	24.50	622	16	400	110	84	18.00	457	18.12	460	31.88	810	18	450	168	117		
6	150	22.00	559	22.12	562	29.50	750	18	450	230	192	24.00	610	24.12	613	41.38	1050	20	500	365	238		
8	200	26.00	660	26.12	663	36.50	927	20	500	410	350	29.00	737	29.12	740	53.50	1360	24	600	665	538		
10	250	31.00	787	31.12	790	44.88	1140	24	600	770	680	33.00	838	33.12	841	61.88	1570	24	600	1250	1060		
12	300	33.00	838	33.12	841	53.12	1350	24	600	1140	1030	--	--	--	--	--	--	--	--	--	--	--	
in	mm	in	mm	in	mm	in	mm	in	mm	RF/RTJ	BW	in	mm	in	mm	in	mm	in	mm	in	mm	RF/RTJ	BW

Applicable Standards

- ★ STEEL GLOBE VALVES, BS EN 13709, BS 1873
- ★ STEEL VALVES, ASME B16.34
- ★ FACE TO FACE, ASME B16.10
- ★ END FLANGES, ASME B16.5
- ★ BUTTWELDING ENDS, ASME B16.25
- ★ INSPECTION AND TEST API598

Design Description

- ▲ STRAIGHT PATTERN BODY DESIGN
- ▲ OS & Y, OUTSIDE SCREW AND YOKE
- ▲ BB, BOLTED BONNET
- ▲ YOKE INTEGRAL WITH BONNET
- ▲ RISING STEM AND HANDWHEEL
- ▲ LOOSE DISC, CHOICE OF PLUG OR BALL
- ▲ RENEWABLE SEAT RING
- ▲ IMPACT HANDWHEEL FOR 10' & ABOVE
- ▲ HORIZONTAL SERVICE
- ▲ FLANGED OR BUTTWELDING ENDS
- ▲ AVAILABLE WITH GEAR OPERATOR

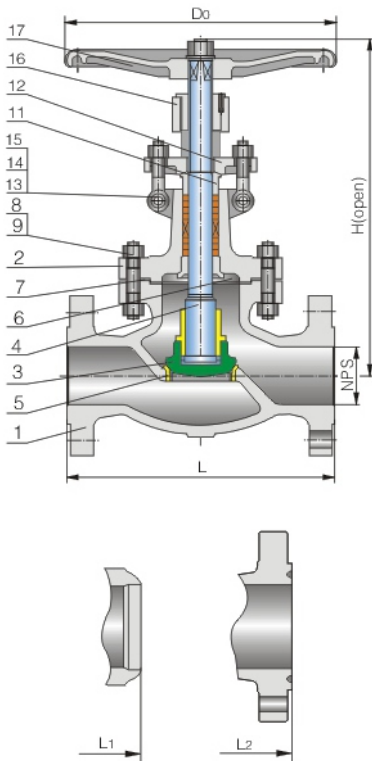

Materials of Parts

No	Part Name	ASTM Material				
		Carbon Steel		Alloy Steel	Stainless Steel	
1	Body	A216-WCB	A352-LCB	A217-WC6	A351-CF8	A351-CF8M
2	Bonnet	A216-WCB	A352-LCB	A217-WC6	A351-CF8	A351-CF8M
3	Disk	A105+Cr13	A350-LF2	A182-F11+HF	A351-CF8	A351-CF8M
4	Stem	A182-F6a	A182-F6a	A182-F11	A276-304	A182-F316
5	Seat Ring	A105+Cr13	A350-LF2	A182-F11+HF	A351-CF8	A351-CF8M
6	Backseat	A276-420	A276-420	A276-304	A276-304	A182-F316
7	Gasket	Spiral wound (Graphite+304)				
8	Bonnet Stud	A193-B7	A320-L7	A193-B16	A193-B8	A193-B8
9	Bonnet Nut	A194-2H	A194-4	A194-7	A194-8	A194-8
10	Packing	Graphite				
11	Gland	A182 F6a	A182F6a	182-F6a	A182-F304	A182-F316
12	Gland Flange	A216-WCB	A216-WCB	A216-WCB	A351-CF8	A351-CF8M
13	Eyebolt Pin	Carbon Steel	Carbon Steel	A276-420	A276-304	A276-316
14	Eyebolt	A193-B7	A320-L7	A193-B16	A193-B8	A193-B8
15	Eyebolt Nut	A194-2H	A194-4	A194-7	A194-8	A194-8
16	Yokesleeve	Aluminium-Bronze				
17	Handwheel	Malleble Iron				

- Notes: 1) Ductile Ni-resist Optional.
 2) Disc and seat ring may either be solid facing material or a base material equal to or better than the body/bonnet material with facing as shown.
 3) Sealing material according to client's demand.

Dimensions Data ANSI Class 1500Lb

ANSI Class 2500Lb

NPS	DN	L/L1 (RF/BW)		L2 (RTJ)		H (Open)		Do		WT(kg)		L/L1 (RF/BW)		L2 (RTJ)		H (Open)		Do		WT(kg)	
		in	mm	in	mm	in	mm	in	mm	in	mm	in	mm	in	mm	in	mm	in	mm	in	mm
2	50	14.50	368	14.62	371	22.00	560	13	320	68	57	17.75	451	17.88	454	25.50	650	16	400	97	72
2½	65	16.50	419	16.62	422	23.25	590	16	400	97	81	20.00	508	20.50	414	28.12	715	18	450	138	95
3	80	18.50	470	18.62	473	29.50	750	18	450	116	95	22.75	578	23.00	584	32.50	825	20	500	167	108
4	100	21.50	546	21.62	549	36.00	915	20	500	215	184	26.50	673	26.88	683	47.00	1195	24	600	305	196
6	150	27.75	705	28.00	711	48.62	1235	24	600	445	347	36.00	914	36.50	927	70.50	1790	28	700	633	351
8	200	32.75	832	33.12	841	65.00	1650	28	700	795	635	--	--	--	--	--	--	--	--	--	--
in	mm	in	mm	in	mm	in	mm	in	mm	RF/RTJ	BW	in	mm	in	mm	in	mm	in	mm	RF/RTJ	BW

Applicable Standards

- ★ STEEL GLOBE VALVES, API 602
- ★ STEEL VALVES, ASME B16.34
- ★ FACE TO FACE, MANUFACTURER STANDARD
- ★ FACE TO FACE, FLANGED, ASME B16.10
- ★ END FLANGES, ASME B16.5
- ★ BUTTWELDING ENDS, ASME B16.25
- ★ SOCKET WELDING ENDS, ASME B16.11
- ★ SCREWED ENDS, ASME B1.20.1
- ★ INSPECTION AND TEST API598

Design Description

- ▲ OUTSIDE SCREW AND YOKE (OS&Y)
- ▲ BOLTED BONNET
- ▲ CHOICE OF WC, WELDING BONNET
- ▲ LOOSE DISC, CHOICE OF PLUG OR BALL
- ▲ SEAT RINGS INTEGRAL WITH BODY
- ▲ YOKE INTEGRAL WITH BONNET
- ▲ RISING STEM AND HANDWHEEL
- ▲ SW, SOCKET-WELDING ENDS
- ▲ SC, SCREWED ENDS
- ▲ BW, BUTTWELDING ENDS

Materials of Parts

No	Part Name	ASTM Material			
		CS	Alloy Steel	Stainless Steel	
1	Body	A105	A182-F11	A182-F304	A182-F316
2	Bonnet	A105	A182-F11	A182-F304	A182-F316
3	Disc	A182-F6a	A182-F6a+HF	A182-F304	A182-F316
4	Stem	A276-410	A182-F11	A276-304	A276-316
5	Gasket	Spiral wound (Graphite+304)		Spiral wound (Graphite+316)	
6	Bonnet Stud	A193-B7	A193-B16	A193-B8	A193-B8
7	Packing	Graphite			
8	Gland	A276-410	A276-410	A276-304	A276-316
9	Gland Flange	A105	A105	A182-F304	A182-F314
10	Eyebolt Pin	A276-410		A276-304	A276-316
11	Eyebolt	A193-B7	A193-B16	A193-B8	A193-B8
12	Eyebolt Nut	A194-2H	A194-4	A194-8	A194-8
13	Yokesleeve	A276-410			
14	Handwheel	Malleble iron			
15	Handwheel Nut	Carbon steel			

- Notes: 1) Seat integral with body.
 2) Spiral wound construction.
 3) Sealing material according to client's demand.

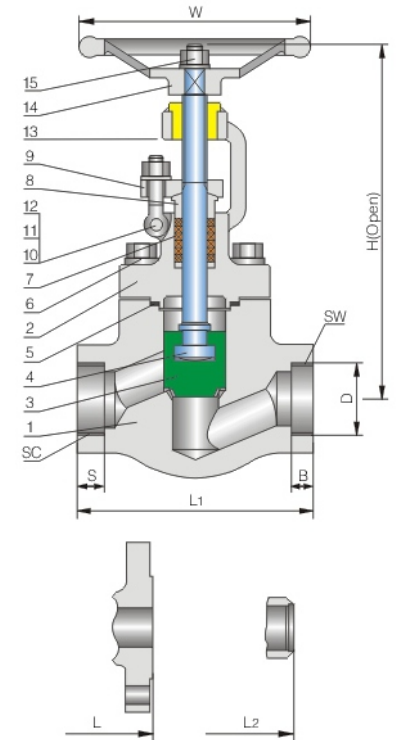

Dimensions Data

NPS DN	Unit	L1 ¹ /L2	L(Flanged Ends)			d	SW		SC		H(Open)	DO	WT ²¹ (Kg)
			1500lb	300lb	600lb		D	B	NPT	S			
3/8	in	3.12	4.00	6.00	6.50	0.354	0.693	0.378	3/8	0.540	6.50	4.00	3.8/2.8
10	mm	79	102	152	165	9	17.6	9.6	3/8	13.6	164	100	
1/2	in	3.12	4.25	6.00	6.50	0.354	0.858	0.378	1/2	0.535	6.50	4.00	5.6/3.4
15	mm	79	108	152	165	9	21.8	9.6	1/2	13.6	164	100	
3/4	in	3.62	4.62	7.00	7.50	0.512	1.067	0.500	3/4	0.547	6.50	4.00	7.8/4.7
20	mm	92	117	178	190	13	27.1	12.7	3/4	13.9	164	100	
1	in	4.38	5.00	8.00	8.50	0.689	1.331	0.500	1	0.681	8.00	5.00	12.5/9.2
25	mm	111	127	203	216	17.5	33.8	12.7	1	17.3	203	125	
1 1/4	in	4.75	5.50	8.50	9.00	0.906	1.677	0.500	1 1/4	0.709	8.88	6.25	17/10.5
32	mm	120	140	216	229	23	42.6	12.7	1 1/4	18	224	160	
1 1/2	in	6.00	6.50	9.00	9.50	1.142	1.917	0.500	1 1/2	0.724	10.25	6.25	23.5/13.3
40	mm	152	165	229	241	29	48.7	12.7	1 1/2	18.4	260	160	
2	in	6.75	8.00	10.50	11.50	1.378	2.406	0.626	2	0.756	11.88	7.00	38.8/18.9
50	mm	172	203	267	292	35	61.1	15.9	2	19.2	300	180	

- Notes: 1) BW, SW or SC.
 2) 600lb-RF/800lb-(BW/SW/SC)

Applicable Standards

- ★ STEEL GLOBE VALVES, BS EN 13709, BS 1873
- ★ STEEL VALVES, ASME B16.34
- ★ FACE TO FACE, ASME B16.10
- ★ END FLANGES, ASME B16.5
- ★ BUTTWELDING ENDS, ASME B16.25
- ★ INSPECTION AND TEST API598

Design Description

- ▲PSB, PRESSURE SEAL BONNET
- ▲OS & Y, OUTSIDE SCREW AND YOKE
- ▲BB, BOLTED BONNET
- ▲RENEWABLE SEAT RING
- ▲RISING STEM AND HANDWHEEL
- ▲FLANGED OR BUTTWELDING ENDS
- ▲AVAILABLE WITH GEAR OPERATOR

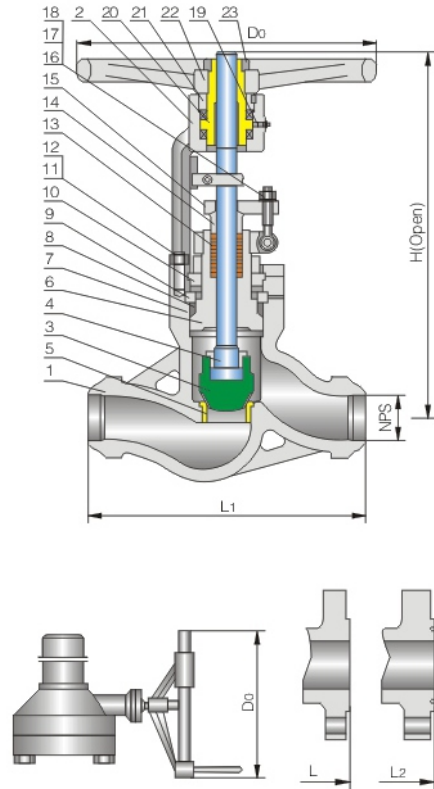

Materials of Parts

No	Part Name	ASTM Material				
		Carbon Steel		1¼Cr-½Mo	Stainless Steel	
1	Body	A216-WCB	A352-LCB	A217-WC6	A351-CF8	A351-CF8M
2	Yoke	A216-WCB	A352-LCB	A217-WC6	A351-CF8	A351-CF8M
3	Disc	A105+HF	A350-LF2+HF	A182-F11+HF	A182-F304+HF	A182-F316+HF
4	Stem	A182-F6a	A182-F6a	A182-F11	A182-F304	A182-F316
5	Seat ring	A105+HF	A350-LF2+HF	A182-F11+HF	A182-F304+HF	A182-F316+HF
6	Bonnet	A105	A352-LF2	A182-F11	A182-F304	A182-F316
7	Gasket	Spiral wound (Graphite+304)				
8	Adaptor	Carbon Steel		A276-420	A276-304	A276-316
9	Retainer Ring	Carbon Steel		A276-420	A276-304	A276-316
10	Yoke Cap	Carbon Steel			Stainless Steel	
11	Bonnet Stud	A193-B7	A320-L7	A193-B7	A193-B8	A193-B8
12	Bonnet Nut	A194-2H	A194-4	A194-2H	A194-8	A194-8
13	Packing	Graphite				
14	Gland	A182 F6a	A182F6a	A182-F6a	A182-F304	A182-F316
15	Glad Flange	A216-WCB	A216 WCB	A216-WCB	A351-CF8	A351-CF8
16	Eyebolt Pin	Carbon Steel	Carbon Steel	A276-420	A276-304	A276-316
17	Eyebolt	A193-B7	A320-L7	A193-B16	A193-B8	A193-B8
18	Eyebolt Nut	A194-2H	A194-4	A194-7	A194-8	A194-8
19	Grease Fitting	Brass-Brone				
20	Yokesleeve	Aluminium-Bronze				
21	Yokesleeve Jam Nut	Carbon Steel				
22	Handwheel	Malleble Iron				
23	Handwheel Nut	Carbon Steel				

- Notes: 1) Graphite Optional.
 2) Ductile Ni-resist optional
 3) Wedge and seat ring may either be solid facing material or a base material equal to or better than the body/bonnet material with facing as shown.

Dimensions Data ANSI Class 900Lb

NPS	2	2½	3	4	6	8	10	12	in
DN	50	65	80	100	150	200	250	300	mm
L1 (BW)	8.50	10.00	12.00	14.00	20.00	26.00	31.00	36.00	in
	216	254	305	356	508	660	787	914	mm
L (RF)	14.50	16.50	15.00	18.00	24.00	29.00	33.00	38.00	in
	368	419	381	457	610	737	838	965	mm
L2 (RTJ)	14.62	16.62	15.12	18.12	24.12	29.12	33.12	38.12	in
	371	422	384	460	613	740	841	968	mm
H (Open)	22	22	22	27	36.38	43.38	50.62	57	in
	557	557	557	685	925	1100	1285	1450	mm
Do	16	16	16	16	28	28	36	36	in
	400	400	400	400	700	700	900	900	mm
Wt(kg)	46	53	68	100	270	450	740	1150	BW
	75	82	95	135	355	680	1050	1480	RF/RTJ

Applicable Standards

- ★ STEEL GLOBE VALVES, BS EN 13709/API 600
- ★ STEEL VALVES, ASME B16.34
- ★ FACE TO FACE, ASME B16.10
- ★ END FLANGES, ASME B16.5
- ★ BUTTWELDING ENDS, ASME B16.25
- ★ INSPECTION AND TEST API598

Design Description

- ▲PSB, PRESSURE SEAL BONNET
- ▲OS & Y, OUTSIDE SCREW AND YOKE
- ▲BB, BOLTED BONNET
- ▲RENEWABLE SEAT RING
- ▲RISING STEM AND HANDWHEEL
- ▲FLANGED OR BUTTWELDING ENDS
- ▲AVAILABLE WITH GEAR OPERATOR

Materials of Parts

No	Part Name	ASTM Material				
		Carbon Steel		1¼Cr-½Mo	Stainless Steel	
1	Body	A216-WCB	A352-LCB	A217-WC6	A351-CF8	A351-CF8M
2	Yoke	A216-WCB	A352-LCB	A217-WC6	A351-CF8	A351-CF8M
3	Disc	A105+HF	A350-LF2+HF	A182-F11+HF	A182-F304+HF	A182-F316+HF
4	Stem	A182-F6a	A182-F6a	A182-F11	A182-F304	A182-F316
5	Seat ring	A105+HF	A350-LF2+HF	A182-F11+HF	A182-F304+HF	A182-F316+HF
6	Bonnet	A105	A352-LF2	A182-F11	A182-F304	A182-F316
7	Gasket	Spiral wound (Graphite+304) Spiral wound (Graphite+316)				
8	Adaptor	Carbon Steel		A276-420	A276-304	A276-316
9	Retainer Ring	Carbon Steel		A276-420	A276-304	A276-316
10	Yoke Cap	Carbon Steel			Stainless Steel	
11	Bonnet Stud	A193-B7	A320-L7	A193-B7	A193-B8	A193-B8
12	Bonnet Nut	A194-2H	A194-4	A194-2H	A194-8	A194-8
13	Packing	Graphite				
14	Gland	A182 F6a	A182F6a	A182-F6a	A182-F304	A182-F316
15	Glad Flange	A216-WCB	A216 WCB	A216-WCB	A351-CF8	A351-CF8
16	Eyebolt Pin	Carbon Steel	Carbon Steel	A276-420	A276-304	A276-316
17	Eyebolt	A193-B7	A320-L7	A193-B16	A193-B8	A193-B8
18	Eyebolt Nut	A194-2H	A194-4	A194-7	A194-8	A194-8
19	Grease Fitting	Brass-Brone				
20	Yokesleeve	Aluminium-Bronze				
21	Yokesleeve Jam Nut	Carbon Steel				
22	Handwheel	Malleble Iron				
23	Handwheel Nut	Carbon Steel				

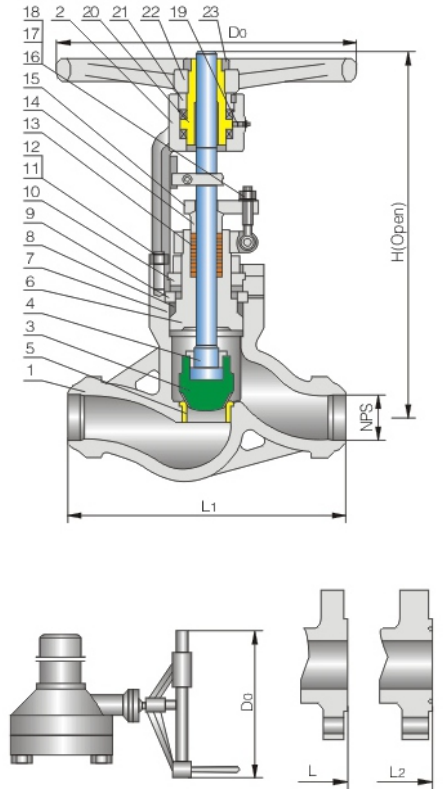

- Notes: 1) Graphite Optional.
 2) Ductile Ni-resist optional
 3) Wedge and seat ring may either be solid facing material or a base material equal to or better than the body/bonnet material with facing as shown.

Dimensions Data

ANSI Class 1500Lb

ANSI Class 2500Lb

NPS	2	2½	3	4	6	8	2	2½	3	4	6	in
DN	50	65	80	100	150	200	50	65	80	100	150	mm
L1 (BW)	8.50	10.00	12.00	16.00	22.00	28.00	11.00	13.00	14.50	18.00	24.00	in
	216	254	305	406	559	711	279	330	368	457	610	mm
L (RF)	14.50	16.50	18.50	21.50	27.75	32.75	17.75	20.00	22.75	26.50	36.00	in
	368	419	470	546	705	832	451	508	578	673	914	mm
L2 (RTJ)	14.62	16.62	18.62	21.62	28.00	33.12	17.88	20.50	23.00	26.88	36.50	in
	371	422	473	549	711	842	454	514	584	683	927	mm
H (Open)	22	22	24.38	30	44.62	54.75	23.38	23.38	28	32.25	49.62	in
	557	557	620	760	1135	1390	595	595	710	820	1260	mm
Do	16	18	20	24	28	36	16	20	24	28	36	in
	400	450	500	600	700	900	400	500	600	700	900	mm
Wt(kg)	57	65	90	190	450	730	65	78	125	155	480	BW
	86	112	162	240	580	950	115	136	205	275	860	RF/RTJ

Applicable Standards

- ★ STEEL GLOBE VALVES, BS EN 13709, BS 1873
- ★ STEEL VALVES, ASME B16.34
- ★ FACE TO FACE, ASME B16.10
- ★ END FLANGES, ASME B16.5
- ★ BUTTWELDING ENDS, ASME B16.25
- ★ INSPECTION AND TEST API598

Design Description

- ▲ STRAIGHT PATTERN BODY DESIGN
- ▲ OS & Y, OUTSIDE SCREW AND YOKE
- ▲ BB, BOLTED BONNET
- ▲ YOKE INTEGRAL WITH BONNET
- ▲ RISING STEM AND HANDWHEEL
- ▲ DOUBLE DISC, CHOICE OF PLUG OR BALL
- ▲ RENEWABLE SEAT RING
- ▲ IMPACT HANDWHEEL FOR 10" & ABOVE
- ▲ HORIZONTAL SERVICE
- ▲ FLANGED OR BUTTWELDING ENDS
- ▲ AVAILABLE WITH BG OPERATOR

Standard Material Specifications

No	Part Name	ASTM Material							
		Carbon Steel	2.5Ni	3.5Ni	304 Type	316 Type	304L Type	316L Type	20 Alloy
1	Body	A352 LCB	A352 LC2	A352 LC3	A351 LF8	A351 CFM8	A351 CF3	A351 CF3M	A351 CF7M
2	Bonnet	A352 LCB	A352 LC2	A352 LC3	A351 CF8	A351 CFM8	A351 CF3	A351 CF3M	A351 CF7M
3	Disc	A350 LF2+304*1	LF3+304	LF3+304	A182 F304	F316	F304L	F316L	20-Alloy
4	Stem	A182 F304	A182 F304	A182 F304	A182 F304	A182 F316	A182 F304L	A182 F316L	20-Alloy
5	Seat Ring	A350 LF2+304*1	A182 F304+HF	A182 F304+HF	NA				NA
6	Back Seat	A276 304	A276 304	A276 304	NA				NA
7A	Bonnet Gasket	304+graphite	304+graphite	304+graphite	304+graphite	316+graphite	304L+graphite	316L+graphite	316+graphite
7B	Ring Gasket	A182 F304	A182 F304	A182 F304	A182 F304	A182 F316	A182 F304L	A182 F316L	20-Alloy
8	Bonnet Bolt	A320 L7	A320 L7	A320 L7	A193 B8	A193 B8M	A193 B8M	A193 B8M	A193 B8M
9	Bonnet Nut	A194 4	A194 4	A194 4	A194 8	A194 8M	A194 8	A194 8M	A194 8M
10	Packing	Graphite	Graphite	Graphite	Graphite*2	Graphite*2	Graphite*2	Graphite*2	Graphite*2
11	Gland	A276 410	A276 304	A276 304	A276 304	A276 316	A276 304L	A276 316L	20-Alloy
12	Gland Flange	A276 WCB			A351 CF8	A351 CF8	A351 CF8	A351 CF8	A351 CF8
13	Eyebolt	A320 L7	A320 L7	A320 L7	A193 B8	A193 B8	A193 B8	A193 B8	A193 B8
14	Eyebolt Nut	A194 4	A194 4	A194 4	A194 8	A194 8	A194 8	A194 8	A194 8
15	Eyebolt Pin	A276 410	A276 410	A276 410	A276 304	A276 304	A276 304	A276 304	A276 304
16	Grease Fitting	Commercial			Commercial				Commercial
17	Yoke Sleeve	Bronze	Bronze*3	Bronze*3	Bronze				Bronze
18	Hand Wheel	Malleable iron			Malleable iron				Malleable iron
19	Wheel Nut	Carbon Steel							
*1	PN>600 CLASS seal face will be HF								
*2	PTFE Optional								
*3	Ductile Ni-Resist iron Optional								
NA	Integral with vessel								

Dimensions Data ANSI Class 150

NPS	in	2	2½	3	4	6	8	10	12	14	16	18	
	mm	50	65	80	100	150	200	250	300	350	400	450	
L & L1	in	8.0	8.5	9.5	11.5	16.0	19.5	24.5	27.5	31.0	36.0	38.5	
	mm	203	216	241	292	406	495	622	698	787	914	978	
H	in	15.3	14.8	17.0	19.5	22.6	28.0	31.4	39.1	54.6	53.4	78.0	
	mm	383	376	433	495	574	710	797	992	1387	1356	1980	
W	in	7.9	8.8	8.8	9.8	14.0	14.0	17.7	17.7	22.0	22.0	24.0	
	mm	200	224	224	250	355	355	450	450	560	560	610	
WT (kg)	RF	lb	44.1	77.2	88.2	123.5	229.3	401.3	650.5	904	1510	1985	3960
		Kg	20	35	40	56	104	182	295	410	685	900	1800
	BW	lb	33.1	66.2	70.6	90.4	183.0	330.8	496.1	728	1312	1764	3638.3
		Kg	15	30	32	41	83	150	225	330	595	800	1650

Dimensions Data ANSI Class 300

NPS	in	2	2½	3	4	6	8	10	12	14	16	
	mm	50	65	80	100	150	200	250	300	350	400	
L & L1	in	10.5	11.5	12.5	14.0	17.5	22.0	24.5	28.0	39.0	42.0	
	mm	267	292	318	356	444	559	622	711	991	1067	
L2	in	11.12	12.12	13.12	14.62	18.12	22.62	25.12	28.62	39.62	42.62	
	mm	283	308	333	371	460	575	638	727	1006	1083	
H	in	15.6	16.3	18.2	21.7	29.2	31.5	44.6	46.1	56.5	70.7	
	mm	396	415	462	550	741	287.5	1132	1172	1435	1797	
W	in	7.9	8.8	9.8	14.0	17.7	22.0	22.0	28.0	28.0	31.5	
	mm	200	224	250	355	450	560	560	710	710	800	
WT (kg)	RF	lb	70.6	92.6	141.0	220.5	419.0	595.4	1163.7	2240	2546.8	3748.5
		kg	32	42	64	100	190	270	530	1016	1155	1700
	BW	lb	66.2	66.2	105.89	194.0	328.5	441	970.2	1997.7	2216	3309.7
		kg	30	30	48	88	149	200	440	906	1005	1501

Dimensions Data ANSI Class 600

NPS	in	2	2½	3	4	6	8	10	12	14	16	
	mm	50	65	80	100	150	200	250	300	350	400	
L & L1	in	11.5	13.0	14.0	17.0	22.0	26.0	31.0	33.0	35.0	39.0	
	mm	292	330	356	432	559	660	787	818	889	991	
L2	in	11.62	13.12	14.12	17.12	22.12	26.12	31.12	33.12	35.12	39.12	
	mm	295	333	359	435	562	664	792	841	892	994	
H	in	16.0	19.8	19.9	22.4	29.9	51.8	59.5	69.9	70.9	76.0	
	mm	407	502	505	165	759	1315	1511	1775	1800	1930	
W	in	8.8	9.8	11.0	14.0	17.7	28.0	31.5	35.4	35.4	35.4	
	mm	224	250	280	355	450	710	800	900	900	900	
WT (kg)	RF	lb	94.8	154.4	172.0	300.0	619.6	1301	2099	3528	5953.5	7938.0
		kg	43	70	78	136	281	590	952	1600	2700	3600
	BW	lb	72.8	121.3	132.3	216.1	454.2	1125	1746	3263.45	5534.6	7386.8
		kg	33	55	60	98	206	510	792	1480	2510	3350

- Check Valve
- Cast Steel Check Valve
- Forged Steel Check Valve
- Pressure Seal, Cast Steel Check Valve
- Cryogenic Check Valve

Check Valve

The check valve can also be called as one-way valve and acts at preventing the medium in the pipeline from back-flow. It belongs to the category of automatic valve and is used mainly with the pipeline where the medium flows in one way in order to prevent any accident from happening. Along with different actions and working conditions, there are lift, swing, butterfly, diaphragm etc. several types and made of different materials, it can be separately used for water, steam, oil, nitric acid, acetic acid, oxidizing media, urea etc, multiple media.

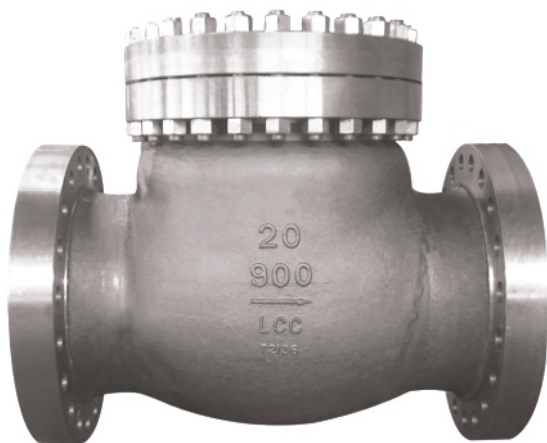

Design

ADVANCED TECHNOLOGY cast steel globe valves are designed and manufactured to provide maximum service life and dependability. All check valves meet the design requirements of American Petroleum Institute Standard API 6D, BS 1868 and generally conform to American Society of Mechanical Engineers standard ASME B16.34. Valves are available in a complete range of body/bonnet material and trims.

Range of Materials

Standard body/bonnet materials include grades of carbon, low alloy and stainless steels. For special applications they can be supplied in other grades of alloy and stainless steel. There's a full range of trim materials to match any service. Optional packing and gasket materials are available for a full range of service conditions.

Available Modifications for ADVANCED TECHNOLOGY Cast Steel Valves

- Trim Changes
- End Connection Modifications
- Packing and Gasket Changes
- Operator Mounting
- Handwheel Extensions
- Pressure Equalizing
- Customer Specified Coatings
- Weld End Bore Changes
- Oxygen & Chlorine Cleaning & Packaging

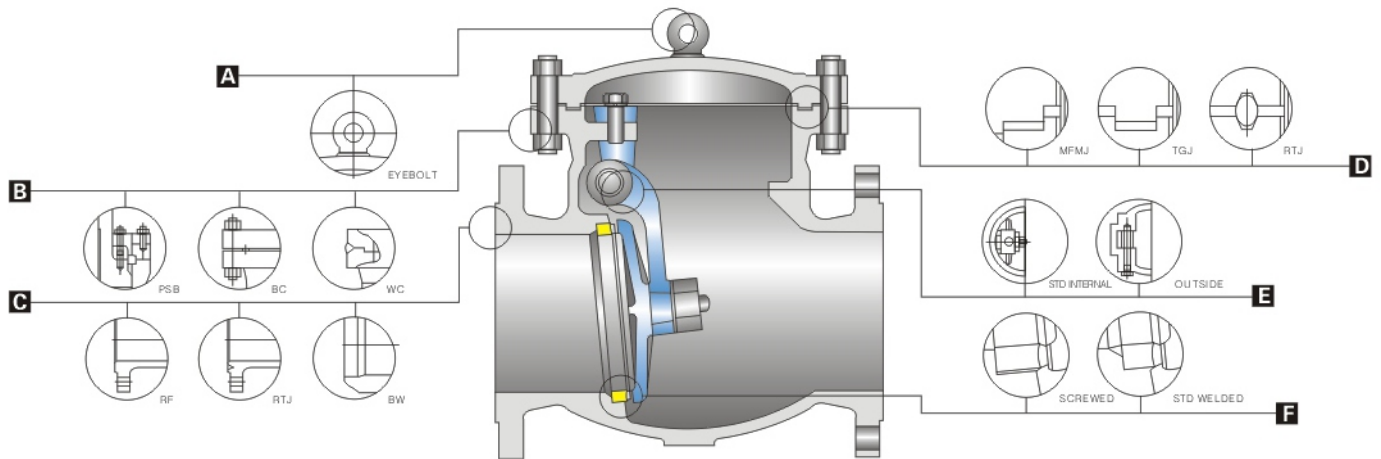

A Eyebolt

For 150Lb-8", 300Lb-8", 600Lb-6, 900Lb/1500Lb/2500Lb-4" & Over

B BC

Bolted bonnet and pressure seal cover in services requiring frequent cycling or with high pressure / temperature variations.

C End Connections

A choice of Flanged, RTJ Flanged or Buttwelding end for piping flexibility.

D Body-to-Cover Joint

A male and Female joint or Tongue and Groove joint is used 150Lb to 600Lb valves. Ring joint is used in the body to cover connection in 900Lb & higher rated valves.

E Outside Lever and Weight

All external hinge pin swing check valves 12" and smaller are available with an optional outside lever and weight. Internal hinge available with all swing check valves.

F Seat Rings

Separate heavy duty. Full Ported rings for easy maintenance. Screwed or welded connections into body.

HCU Weighted Mechanical Accumulator

This design can be used to either dampen or assist closing of the check valve disc depending on orientation. By using the Hydraulic Control Unit to buffer action the disc, the valve opens at lower flow rates.

Applicable Standards

- ★ STEEL CHECK VALVES, API 6D, BS 1868
- ★ STEEL CHECK VALVES, ISO14313
- ★ STEEL VALVES, ASME B16.34
- ★ FACE TO FACE, ASME B16.10
- ★ END FLANGES, ASME B16.5
- ★ BUTTWELDING ENDS, ASME B16.25
- ★ INSPECTION AND TEST API 598/API 6D

Design Description

- ▲ BB. BOLTED COVER
- ▲ SWING TYPE, ANTI-ROTATION DISC
- ▲ RENEWABLE SEAT RINGS
- ▲ NON-PENETRATE DISC SHAFT
- ▲ HORIZONTAL OR VERTICAL SERVICE
- ▲ FLANGED OR BUTT WELDING ENDS

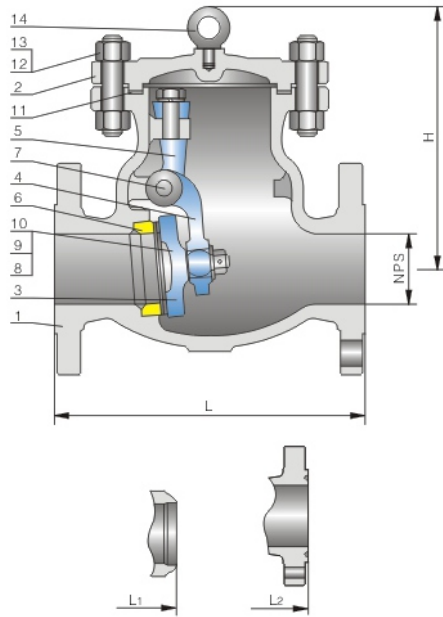

Materials of Parts

No	Part Name	ASTM Material				
		Carbon Steel		Alloy Steel	Stainless Steel	
1	Body	A216-WCB	A352-LCB	A217-WC6	A351-CF8	A351-CF8M
2	Cover	A216-WCB	A352-LCB	A217-WC6	A351-CF8	A351-CF8M
3	Disc	WCB+Cr13	WCB	WC6+HF	CF8	CF8M
4	Arm	A216-WCB	A352-LCB	A217-WC6	A351-CF8	A351-CF8M
5	End Frame	A216-WCB	A352-LCB	A217-WC6	A351-CF8	A351-CF8M
6	Seat Ring	A105+cR13	A350-LF2	A182-F11+HF	A276-304	A276-316
7	Hinge Pin	A276-420	A276-420	A276-304	A276-304	A276-316
8	Disc Washer	Carbon Steel		A276-304	304	316
9	Disc Nut	Carbon Steel		A194-7	A194-8	A194-8
10	Disc Nut Pin	Carbon Steel		A276-420	A276-304	A276-316
11	Gasket	(Graphite+304) ²⁾		(Graphite+316) ²⁾	(Graphite+304) ²⁾	(Graphite+304) ²⁾
12	Stud	A193-B7	A320-L7	A193-B16	A193-B8	A193-B8
13	Nut	A194-2H	A194-4	A194-7	A194-8	A194-8
14	Eyebolt ²⁾	Carbon Steel				

- Notes: 1) Cast steel disc for NPS 4" and above.
 2) NPS 6" & larger.
 3) Disc and seat ring may either be solid facing material or a base material equal to or better than the body/bonnet material with facing as shown.

Dimensions Data ANSI Class 150Lb

NPS	2	2½	3	4	6	8	10	12	14	16	18	20	24	26	28	30	36	in
DN	50	65	80	100	150	200	250	300	350	400	450	500	600	650	700	750	900	mm
L/L1 (RF/BW)	8.00	8.50	9.50	11.50	14.00	19.50	24.50	27.50	31.00	34.00	38.50	38.50	51.00	51.00	57.00	60.00	77.00	in
	203	216	241	292	356	495	622	699	787	864	978	978	1295	1295	1484	1524	1956	mm
L2 (RTJ)	8.50	9.00	10.00	12.00	14.50	20.00	25.00	28.00	31.50	34.50	39.00	39.00	51.50	--	--	--	--	in
	216	229	254	305	368	508	635	711	800	876	991	991	1308	--	--	--	--	mm
H	6.00	6.50	6.88	8.00	11.50	13.88	15.38	17.00	18.75	20.62	22.88	24.62	34.75	37.00	37.00	38.62	48.00	in
	152	165	175	204	293	353	390	432	475	525	582	627	883	940	940	980	1220	mm
Wt(kg)	14	20	25	40	71	118	177	263	353	542	632	855	970	1600	1600	1990	2760	RF/RTJ
	10	12	17	29	57	96	143	227	295	468	552	755	831	1420	1420	1760	2230	NW

Dimensions Data ANSI Class 300Lb

NPS	2	2½	3	4	6	8	10	12	14	16	18	20	24	26	28	30	36	in
DN	50	65	80	100	150	200	250	300	350	400	450	500	600	650	700	750	900	mm
L/L1 (RF/BW)	10.50	11.50	12.50	14.00	17.50	21.00	24.50	28.00	33.00	34.00	38.50	40.00	53.00	53.00	59.00	62.75	82.00	in
	267	292	318	356	445	533	622	711	838	864	978	1016	1346	1346	1499	1594	2083	mm
L2 (RTJ)	11.12	12.12	13.12	14.62	18.12	21.62	25.00	28.62	33.62	34.62	39.12	40.75	53.88	54.00	60.00	63.75	--	in
	283	308	333	371	460	549	638	727	854	879	994	1035	1368	1372	1524	1619	--	mm
H	6.00	6.50	6.88	8.00	11.50	13.88	15.38	17.00	18.75	20.62	22.88	24.62	34.75	35.88	37.00	38.62	48.00	in
	152	165	175	204	292	353	390	432	475	525	582	627	883	910	940	980	1220	mm
Wt(kg)	16	23	29	46	82	136	204	302	405	625	730	985	1115	1465	1840	2290	3180	RF/RTJ
	11	13	18	31	61	103	155	245	315	503	593	812	895	1205	1525	1895	2395	NW

Applicable Standards

- ★ STEEL CHECK VALVES, API 6D, BS 1868
- ★ STEEL CHECK VALVES, ISO14313
- ★ STEEL VALVES, ASME B16.34
- ★ FACE TO FACE, ASME B16.10
- ★ END FLANGES, ASME B16.5
- ★ BUTTWELDING ENDS, ASME B16.25
- ★ INSPECTION AND TEST API 598/API 6D

Design Description

- ▲ BB. BOLTED COVER
- ▲ SWING TYPE, ANTI-ROTATION DISC
- ▲ RENEWABLE SEAT RINGS
- ▲ NON-PENETRATE DISC SHAFT
- ▲ HORIZONTAL OR VERTICAL SERVICE
- ▲ FLANGED OR BUTT WELDING ENDS

Materials of Parts

No	Part Name	ASTM Material				
		Carbon Steel		Alloy Steel	Stainless Steel	
1	Body	A216-WCB	A352-LCB	A217-WC6	A351-CF8	A351-CF8M
2	Cover	A216-WCB	A352-LCB	A217-WC6	A351-CF8	A351-CF8M
3	Disc	WCB+Cr13	WCB	WC6+HF	CF8	CF8M
4	Arm	A216-WCB	A352-LCB	A217-WC6	A351-CF8	A351-CF8M
5	End Frame	A216-WCB	A352-LCB	A217-WC6	A351-CF8	A351-CF8M
6	Seat Ring	A105+Cr13	A350-LF2	A182-F11+HF	A276-304	A276-316
7	Hinge Pin	A276-420	A276-420	A276-304	A276-304	A276-316
8	Disc Washer	Carbon Steel		A276-304	304	316
9	Disc Nut	Carbon Steel		A194-7	A194-8	A194-8
10	Disc Nut Pin	Carbon Steel		A276-420	A276-304	A276-316
11	Gasket	(Graphite+304) ²⁾		(Graphite+316) ²⁾	(Graphite+304) ²⁾	(Graphite+304) ²⁾
12	Stud	A193-B7	A320-L7	A193-B16	A193-B8	A193-B8
13	Nut	A194-2H	A194-4	A194-7	A194-8	A194-8
14	Eyebolt ²⁾	Carbon Steel				

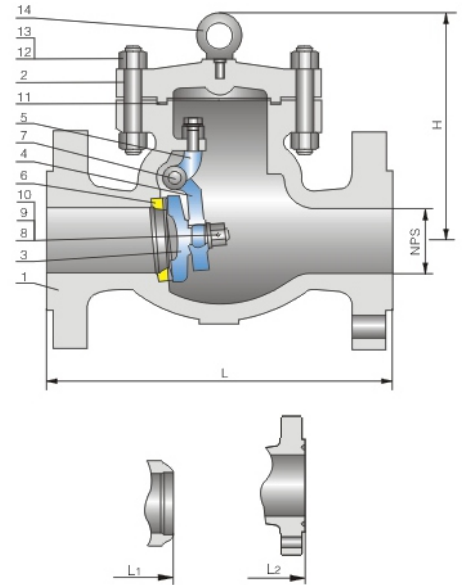

- Notes: 1) Cast steel disc for NPS 4" and above.
 2) NPS 6" & larger.
 3) Disc and seat ring may either be solid facing material or a base material equal to or better than the body/bonnet material with facing as shown.

Dimensions Data ANSI Class 600Lb

NPS	2	2½	3	4	6	8	10	12	14	16	18	20	24	in
DN	50	65	80	100	150	200	250	300	350	400	450	500	600	mm
L/L1 (RF/BW)	11.50	13.00	14.00	17.00	22.00	26.00	31.00	33.00	35.00	39.00	43.00	47.00	55.00	in
	292	330	356	432	559	660	787	838	889	991	1092	1194	1397	mm
L2 (RTJ)	11.62	13.12	14.12	17.12	22.12	26.12	31.12	33.12	35.12	39.12	43.12	47.25	55.38	in
	295	333	359	435	562	664	791	841	892	994	1095	1200	1407	mm
H	7.50	8.00	8.75	10.00	14.50	17.50	19.25	21.38	23.38	25.75	28.75	31.00	43.50	in
	190	205	222	255	368	445	490	540	595	655	730	785	1105	mm
Wt(kg)	24	35	44	70	125	207	310	460	615	945	1105	1495	1695	RF/RTJ
	16	19	26	44	87	147	220	350	452	720	845	1160	1280	BW

Dimensions Data ANSI Class 900Lb

NPS	2	2½	3	4	6	8	10	12	14	16	18	20	24	in
DN	50	65	80	100	150	200	250	300	350	400	450	500	600	mm
L/L1 (RF/BW)	14.50	16.50	15.00	18.00	24.00	29.00	33.00	38.00	40.50	44.50	48.00	52.00	--	in
	368	419	381	457	610	737	838	965	1029	1130	1219	1321	--	mm
L2 (RTJ)	14.62	16.62	15.12	18.12	24.12	29.12	33.12	38.12	40.88	44.88	48.50	52.50	--	in
	371	422	384	460	613	740	841	968	1038	1140	1232	1334	--	mm
H	9.50	10.00	11.00	12.50	18.12	22.00	24.00	26.50	29.38	32.00	33.50	38.75	--	in
	240	256	278	320	460	560	610	675	745	815	850	985	--	mm
Wt(kg)	37	54	68	109	195	321	481	711	956	1468	1870	2316	--	RT/RTJ
	21	25	34	58	115	194	290	461	597	950	1210	1533	--	BW

Applicable Standards

- ★ STEEL CHECK VALVES, API 6D, BS 1868
- ★ STEEL CHECK VALVES, ISO14313
- ★ STEEL VALVES, ASME B16.34
- ★ FACE TO FACE, ASME B16.10
- ★ END FLANGES, ASME B16.5
- ★ BUTTWELDING ENDS, ASME B16.25
- ★ INSPECTION AND TEST API 598/API 6D

Design Description

- ▲ PRESSURE SEAL
- ▲ SWING TYPE, ANTI-ROTATION DISC
- ▲ RENEWABLE SEAT RINGS
- ▲ NON-PENETRATE DISC SHAFT
- ▲ HORIZONTAL OR VERTICAL SERVICE
- ▲ FLANGED OR BUTT WELDING ENDS

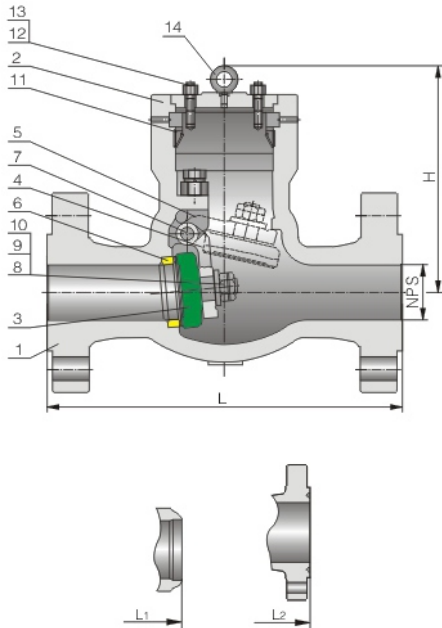

Materials of Parts

No	Part Name	ASTM Material				
		Carbon Steel		Alloy Steel	Stainless Steel	
1	Body	A216-WCB	A352-LCB	A217-WC6	A351-CF8	A351-CF8M
2	Cover	A216-WCB	A352-LCB	A217-WC6	A351-CF8	A351-CF8M
3	Disc	WCB+Cr13	A352-LCB	WC6+HF	CF8	CF8M
4	Arm	A216-WCB	A352-LCB	A217-WC6	A351-CF8	A351-CF8M
5	End Frame	A216-WCB	A352-LCB	A217-WC6	A351-CF8	A351-CF8M
6	Seat Ring	A105+Cr13	A350-LF2	A182-F11+HF	A276-304	A276-316
7	Hinge Pin	A276-420	A276-420	A276-304	A276-304	A276-316
8	Disc Washer	Carbon Steel		A276-304	A351-CF8	A351-CF8M
9	Disc Nut	Carbon Steel		A194-7	A194-8	A194-8
10	Disc Nut Pin	Carbon Steel		A276-420	A276-304	A276-316
11	Gasket	(Graphite+304) ²⁾		(Graphite+316) ²⁾	(Graphite+304) ²⁾	(Graphite+316) ²⁾
12	Stud	A193-B7	A320-L7	A193-B16	A193-B8	A193-B8
13	Nut	A194-2H	A194-4	A194-7	A194-8	A194-8
14	Eyebolt ²⁾	Carbon Steel			A351-CF8	

- Notes: 1) Cast steel disc for NPS 4" and above.
 2) NPS 6" & larger.
 3) Disc and seat ring may either be solid facing material or a base material equal to or better than the body/bonnet material with facing as shown.

Dimensions Data ANSI Class 1500Lb

ANSI Class 2500Lb

NPS	DN	L1/BW		L2 (RTJ)		H			WT(KG)								
		in	mm	in	mm	in	mm	RF/RTJ	BW	in	mm	in	mm	RF/RTJ	BW		
2	50	216		14.62	371	9.50	240	40	29	279	17.88	454	10.75	275	50	35	
2 1/2	65	254		16.62	422	10.00	256	63	47	330	20.25	514	13.25	335	76	55	
3	80	305		18.62	473	13.00	330	70	49	368	23.00	584	13.75	350	85	68	
4	100	406		21.62	549	14.75	375	115	84	457	26.88	683	15.12	385	165	115	
6	150	559		28.00	711	18.88	480	250	152	610	36.50	927	19.50	495	460	225	
8	200	711		33.12	841	23.50	595	470	310	762	40.88	1038	24.62	625	900	580	
10	250	864		39.38	1000	26.00	660	740	470	914	50.88	1292	28.00	712	1300	860	
12	300	991		45.12	1146	29.12	740	1100	710	1041	56.88	1445	35.62	905	1800	1150	
14	350	1067		50.25	1276	30.88	785	1410	910	--	--	--	--	--	--	--	
16	400	1194		55.38	1407	32.88	835	1600	1100	--	--	--	--	--	--	--	
in	mm	in	mm	in	mm	in	mm	RF/RTJ	BW	in	mm	in	mm	in	mm	RF/RTJ	BW

Applicable Standards

- ★ STEEL CHECK VALVES, API 194/API 6D
- ★ STEEL CHECK VALVES, ISO14313
- ★ STEEL VALVES, ASME B16.34
- ★ FACE TO FACE, ASME B16.10
- ★ END FLANGES, ASME B16.5
- ★ INSPECTION AND TEST API 598/API 6D

Design Description

- ▲ ONE PIECE BODY
- ▲ BUTTERFLY SWING TYPE
- ▲ DUAL PLATE DISC, LONG-PATTERN
- ▲ RENEWABLE SPLIT DISC
- ▲ HORIZONTAL OR VERTICAL SERVICE
- ▲ WAFER ENDS
- ▲ AVAILABLE WITH FLANGED ENDS

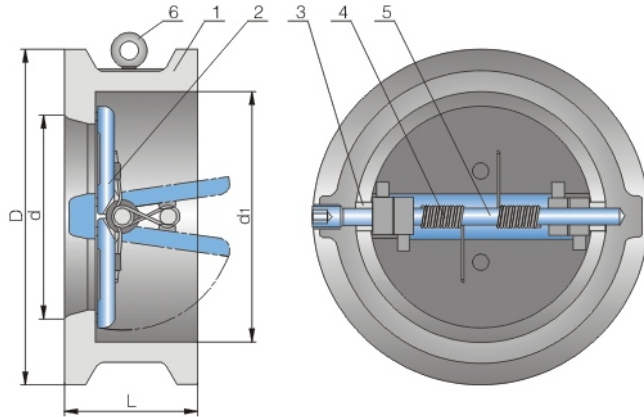

Material of Parts

No	Part Name	ASTM Material				
		Carbon Steel		Alloy Steel	Stainless Steel	
1	Body	A216-WCB	A352-LCB	A217-WC6	A315-CF8	A351-CF8M
2	Plate	WCB+Cr13	A352-LCB	WC6+HF	CF8	CF8M
3	Stop Pin	A276-420	A276-420	A276-304	A276-304	A276-316
4	Back Spring	A313-304	A313-304	A313-304	A313-304	A313-316
5	Hinge Pin	A276-420	A276-420	A276-304	A276-304	A276-316
6	Eyebolt	Carbon Steel				

Notes: 1) NPS 8" & larger.

Dimensions Data ANSI Class 150Lb

NPS	2	2½	3	4	6	8	10	12	14	16	18	20	24	in
DN	50	65	80	100	150	200	250	300	350	400	450	500	600	mm
L	2.38	2.62	2.88	2.88	3.88	5.00	2.75	7.12	7.25	7.50	8.00	8.62	8.75	in
	60	67	73	73	98	127	146	181	184	191	203	219	222	mm
D	4.00	4.88	5.38	6.75	8.62	10.88	13.25	16.00	17.62	20.12	21.50	23.75	28.12	in
	103	122	135	173	220	277	337	407	448	512	547	604	715	mm
d	2.00	2.50	3.25	4.00	6.00	8.00	10.00	12.00	13.75	15.75	17.75	19.75	23.62	in
	51	65	80	102	152	203	254	305	350	400	450	500	600	mm
D1	2.25	2.88	3.50	4.25	6.25	8.25	10.50	12.12	14.00	16.00	18.00	19.88	23.75	in
	56	73	88	108	160	210	266	310	355	405	455	505	605	mm
WT	2	3	4	6	13	25	39	54	80	117	138	163	331	kg

Dimensions Data ANSI Class 300Lb

NPS	2	2½	3	4	6	8	10	12	14	16	18	20	24	in
DN	50	65	80	100	150	200	250	300	350	400	450	500	600	mm
L	2.38	2.62	2.88	2.88	3.88	5.00	5.75	7.12	8.75	9.12	10.38	11.50	12.50	in
	60	67	73	73	98	127	146	181	222	232	264	292	318	mm
D	4.25	5.00	5.75	7.00	9.88	12.00	14.12	16.50	19.00	21.12	23.38	25.62	30.38	in
	110	128	147	179	249	305	359	420	483	537	594	652	772	mm
d	2.00	2.50	3.00	4.00	6.00	8.00	10.00	12.00	14.00	16.00	18.00	20.00	24.00	in
	51	65	80	102	152	200	254	305	350	400	450	500	600	mm
D1	2.25	2.88	3.50	4.25	6.38	8.27	10.50	12.25	14.00	16.00	18.00	20.00	24.00	in
	58	73	88	108	160	210	266	310	355	405	455	505	605	mm
WT	3	4	6	8	18	31	51	77	117	190	200	265	410	kg

Applicable Standards

- ★ STEEL CHECK VALVES, API 594/API 6D
- ★ STEEL CHECK VALVES, ISO14313
- ★ STEEL VALVES, ASME B16.34
- ★ FACE TO FACE, ASME B16.10
- ★ END FLANGES, ASME B16.5
- ★ INSPECTION AND TEST, API 598/API 6D

Design Description

- ▲ ONE PIECE BODY
- ▲ BUTTERFLY SWING TYPE
- ▲ DUAL-PLATE DISC, LONG-PATTERN
- ▲ RENEWABLE SPLIT DISC
- ▲ HORIZONTAL OR VERTICAL SERVICE
- ▲ WAFER ENDS
- ▲ AVAILABLE WITH FLANGED ENDS

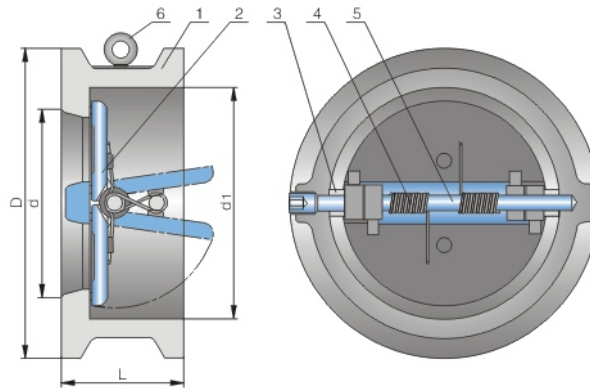

Material of Parts

No	Part Name	ASTM Material				
		Carbon Steel		Alloy Steel	Stainless Steel	
1	Body	A216-WCB	A352-LCB	A217-WC6	A315-CF8	A315-CF8M
2	Plate	WCB+Cr13	A352-LCB	WC6+HF	CF8	CF8M
3	Stop Pin	A276-420	A276-420	A276-304	A276-304	A276-316
4	Back Spring	A313-304	A313-304	A313-304	A313-304	A313-316
5	Hinge Pin	A276-420	A276-420	A276-304	A276-304	A276-316
6	Eyebolt	Carbon Steel				

Notes: 1) NPS 8" & larger.

Dimensions Data ANSI Class 600Lb

ANSI Class 900Lb

NPS	DN	L		D		d		D ₁		WT	L		D		d		D ₁		WT
2	50	2.38	60	4.38	110	2.00	51	2.25	58	4	2.75	70	5.50	140	2.00	51	2.25	58	8
2½	65	2.62	67	5.00	128	2.50	65	2.88	73	5	3.25	83	6.38	162	2.50	65	2.88	73	11
3	80	2.88	73	5.75	147	3.00	80	3.50	88	8	3.25	83	6.50	165	3.00	80	3.50	88	14
4	100	3.12	79	7.50	191	4.00	102	4.25	108	11	4.00	102	8.00	204	4.00	102	4.25	108	20
6	150	5.38	137	10.38	264	6.00	152	6.38	162	26	6.25	159	11.25	286	6.00	152	6.38	162	42
8	200	6.50	165	12.50	318	7.88	200	8.38	212	55	8.12	206	14.00	356	7.88	200	8.38	212	84
10	250	8.38	213	15.62	398	9.88	250	10.50	266	95	9.50	241	17.00	432	9.88	250	10.50	266	145
12	300	9.00	229	17.88	455	12.00	305	12.25	312	140	11.50	292	19.50	495	12.00	305	12.25	312	220
14	350	10.75	273	19.25	490	13.25	337	14.00	355	223	--	--	--	--	--	--	--	--	--
16	400	12.00	305	22.12	562	15.25	387	15.75	400	360	--	--	--	--	--	--	--	--	--
in	mm	in	mm	in	mm	in	mm	in	mm	kg	in	mm	in	mm	in	mm	in	mm	kg

Applicable Standards

- ★ STEEL CHECK VALVES, API 602
- ★ STEEL VALVES, ASME B16.34
- ★ FACE TO FACE, MANUFACTURER STANDARD
- ★ FACE TO FACE, FLANGED, ASME B16.10
- ★ END FLANGES ASME B16.5
- ★ BUTTWELDING ENDS, ASME B16.11
- ★ SOCKET-WELDING ENDS, ASME B16.11
- ★ SCREWED ENDS, ASME B1.20.1
- ★ INSPECTION AND TEST, API 598

Design Description

- ▲ BOLTED COVER
- ▲ CHOICE OF WB, WELDING COVER
- ▲ LIFT OR SWING TYPE
- ▲ SEAT RINGS INTEGRAL WITH BODY OF LIFT
- ▲ HORIZONTAL OR VERTICAL SERVICE
- ▲ SW, SOCKET-WELDING ENDS
- ▲ SC, SCREWED ENDS
- ★ BW, BUTT WELDING ENDS
- ★ FLANGED ENDS

Materials of Parts

No	Part Name	ASTM Material			
		CS	Alloy Steel	Stainless Steel	
1	Body	A105	A182-F11	A182-F304	A182-F316
2	Cover	A105	A182-F11	A182-F304	A182-F316
3	Disc	A182-F6a	A182-F11+HF	A182-F304	A182-F316
4	Hinge	A276-410	A182-F11	A276-304	A276-316
5	Seat	A276-410	A182-F11+HF	A182-F304	A182-F316
6	Gasket	Spiral wound (Graphite+304)		Spiral wound (Graphite+316)	
7	Stud	A193-B7	A193-B16	A193-B8	A193-B8

Notes: 1) Lift type check valve seat ring integral with body.
2) Spiral wound construction.

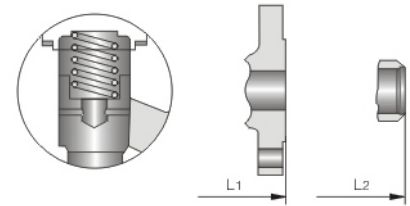
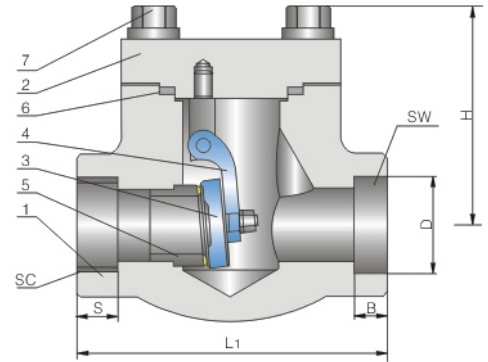

Dimensions Data

NPS DN	Unit	L1"	L (Flanged Ends)			d	SW		SC		H	WT ²¹ (kg)
			150 Lb	300Lb	600Lb		D	B	NPT	S		
3/8	in	3.12	4.00	6.00	6.50	0.354	0.693	0.378	3/8	0.540	2.40	3.8/2.8
10	mm	79	102	152	165	9	17.3	9.6		13.6	61	
1/2	in	3.12	4.25	6.00	6.50	0.354	0.858	0.378	1/2	0.535	2.40	5.6/3.4
15	mm	79	108	152	165	10	21.8	9.6		13.6	61	
3/4	in	3.62	4.62	7.00	7.50	0.512	1.067	0.500	3/4	0.547	2.40	7.8/4.7
20	mm	92	117	178	190	13	27.1	12.7		13.9	61	
1	in	4.38	5.00	8.00	8.50	0.689	1.331	0.500	1	0.681	3.07	12.5/9.2
25	mm	111	127	203	216	17.5	33.8	12.7		17.3	78	
1 1/4	in	4.75	5.50	8.50	9.00	0.906	1.677	0.500	1 1/4	0.709	3.31	17/10.5
32	mm	120	140	216	229	23	42.6	12.7		18	84	
1 1/2	in	4.75	6.50	9.00	9.50	1.142	1.917	0.500	1 1/2	0.724	10.25	23.5/13.3
40	mm	120	165	229	241	30	48.7	12.7		18.4	3.98	
2	in	5.50	8.00	10.50	11.50	1.378	2.406	0.626	2	0.756	4.72	38.8/19.9
50	mm	140	203	267	292	35	61.1	15.9		19.2	120	

Applicable Standards

- ★ STEEL CHECK VALVES, API 594/API 6D
- ★ STEEL C HECK VALVES, ISO 14313
- ★ STEEL VALVESM ASME B16.34
- ★ FACE TO FACE, ASME B16.10
- ★ END FLANGES, ASME B16.5
- ★ INSPECTION AND TEST, API 598/API 6D

Design Description

- ▲ PSB, PRESSURE SEAL BONNET
- ▲ FLAXIBLE DISC, FULLY GUIDED
- ▲ RENEWABLE SEAT RINGS
- ▲ FLANGED OR BUTT WELDING ENDS

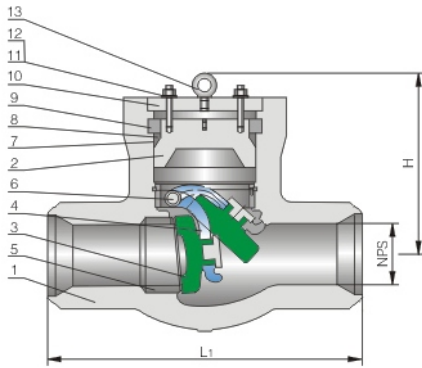

Materials of Parts

No	Part Name	ASTM Material				
		Carbon Steel		Alloy Steel	Stainless Steel	
1	Body	A216-WCB	A352-LCB	A217-WC6	A351-CF8	A351-CF8M
2	Pres. Seal Bonnet	A216-WCB	A352-LCB	A217-WC6	A351-CF8	A351-CF8M
3	Disc	WCB+HF	A352-LCB	WC6+HF	CF8+HF	CF8M+HF
4	Hinge	A216-WCB	A352-LCB	A217-WC6	A351-CF8	A351-CF8M
5	Seat Ring	A105+HF	A350-LF2	A182-F11+HF	A240-304+FL	A240-316+HF
6	Hinge Ring	A276-420	A276-420	A276-304	A276-304	A276-316
7	Bonnet Gasket	Spiral wound (Graphite+304)		Spiral wound (Graphite+316)		
8	Adapter	Carbon Steel		A276-304	A276-304	A276-316
9	Retainer Ring	Carbon Steel		A276-F11	A276-304	A276-316
10	Cover	A216-WCB	A352-LCB	A217-WC6	A351-CF8	A351-CF8M
11	Stud	A193-B7	A320-L7	A193-B16	A193-B8	A193-B8
12	Nut	A194-2H	A194-4	A194-7	A194-8	A94-8
13	Eyebolt	Carbon Steel				

Notes: 1) Graphic Optional.

2) Disc and seat ring may either be solid facing material or a base material equal to or better than the body/bonnet material with facing as shown.

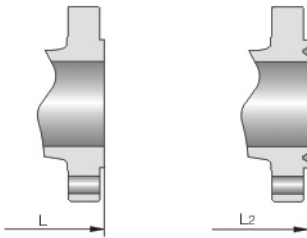

Dimensions Data ANSI Class 900Lb

NPS	2	2½	3	4	6	8	10	12	14	16	in
DN	50	65	80	100	150	200	250	300	350	400	mm
L1 (BW)	8.50	10.00	12.00	14.00	20.00	26.00	31.00	36.00	39.00	43.00	in
	216	254	305	356	508	660	787	914	991	1092	mm
L (RF)	14.50	16.60	15.00	18.00	24.00	29.00	33.00	38.00	40.50	44.50	in
	368	419	381	457	610	737	838	965	1029	1130	mm
L2 (RTJ)	14.62	16.62	15.12	18.12	24.12	29.12	33.12	38.12	40.88	44.88	in
	371	422	384	460	613	740	841	968	1038	1140	mm
H	9.50	9.50	10.00	13.38	15.75	18.12	21.62	24.00	27.00	29.50	in
	240	240	255	340	400	460	550	610	685	750	mm
WT(kg)	22	34	38	71	176	485	761	1125	1345	1490	BW
	44	55	61	116	255	630	940	1433	1710	1820	RF/RTJ

Applicable Standards

- ★ STEEL CHECK VALVES, BS EN 13709/API 600
- ★ STEEL VALVES, B16.34
- ★ FACE TO FACE, ASME B16.10
- ★ END FLANGES, ASME B16.5
- ★ BUTTWELDING ENDS, ASME B16.25
- ★ INSPECTION AND TEST, API 598

Design Description

- ▲ PSB, PRESSURE SEAL BONNET
- ▲ FLAXIBLE DISC, FULLY GUIDED
- ▲ RENEWABLE SEAT RINGS
- ▲ FLANGED OR BUTT WELDING ENDS

Materials of Parts

No	Part Name	ASTM Material				
		Carbon Steel	Alloy Steel	Alloy Steel	Stainless Steel	Stainless Steel
1	Body	A216-WCB	A352-LCB	A217-WC6	A351-CF8	A351-CF8M
2	Pres. Seal Bonnet	A216-WCB	A352-LCB	A217-WC6	A351-CF8	A351-CF8M
3	Disc	WCB+HF	A352-LCB	WC6+HF	CF8+HF	CF8M+HF
4	Hinge	A216-WCB	A352-LCB	A217-WC6	A351-CF8	A351-CF8M
5	Seat Ring	A105+HF	A350-LF2	A182-F11+HF	A240-304+FL	A240-316+HF
6	Hinge Ring	A276-420	A276-420	A276-304	A276-304	A276-316
7	Bonnet Gasket	Spiral wound (Graphite+304)		Spiral wound (Graphite+316)		
8	Adapter	Carbon Steel		A276-304	A276-304	A276-316
9	Retainer Ring	Carbon Steel		A276-F11	A276-304	A276-316
10	Cover	A216-WCB	A352-LCB	A217-WC6	A351-CF8	A351-CF8M
11	Stud	A193-B7	A320-L7	A193-B16	A193-B8	A193-B8
12	Nut	A194-2H	A194-4	A194-7	A194-8	A94-8
13	Eyebolt	Carbon Steel				

Notes: 1) Graphic Optional.

2) Disc and seat ring may either be solid facing material or a base material equal to or better than the body/bonnet material with facing as shown.

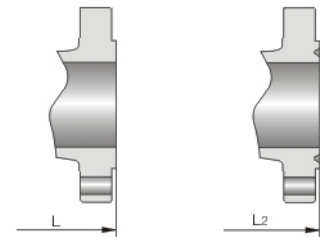
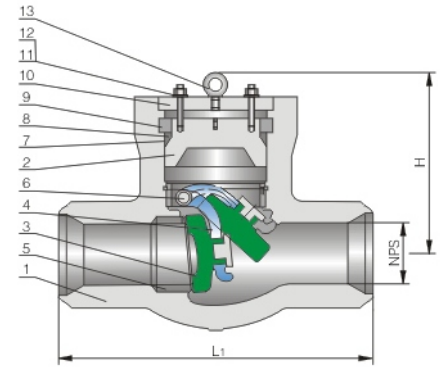

Dimensions Data ANSI Class 1500Lb

ANSI Class 2500Lb

NPS	ANSI Class 1500Lb									ANSI Class 2500Lb									in
	2	2½	3	4	6	8	10	12	14	2	2½	3	4	6	8	10	12	14	
DN	50	65	80	100	150	200	250	300	350	50	65	80	100	150	200	250	300	350	mm
L1 (BW)	8.50	10.00	12.00	16.00	22.00	28.00	34.00	39.00	42.00	11.00	13.00	14.50	18.00	24.00	30.00	36.00	41.00	42.00	in
	216	254	305	406	559	711	864	991	1067	279	330	368	457	610	762	914	1041	1067	mm
L (RF)	14.50	16.50	18.50	21.50	27.75	32.75	39	44.5	49.5	17.75	20.00	22.75	26.50	36.00	40.25	50	56	56	in
	368	419	470	546	705	832	991	1130	1257	451	508	578	673	914	1022	1270	1422	1422	mm
L2 (RTJ)	14.62	16.62	18.62	21.62	28.00	33.12	39.38	45.12	50.25	17.88	20.50	23.00	26.88	36.50	40.88	50.88	56.88	56.88	in
	371	422	473	549	711	842	1000	1146	1276	454	514	584	683	927	1038	1292	1445	1445	mm
H	9.50	9.50	11.88	15.38	18.00	20.62	24.00	27.00	30.00	10.25	10.25	13.75	16.12	18.88	22.38	25.25	32.00	32.00	in
	240	240	300	390	455	525	610	685	760	260	260	350	410	480	570	640	815	815	mm
WT(kg)	22	37	45	78	245	530	815	1213	1555	55	78	95	182	300	630	825	1580	1580	BW
	44	61	110	155	378	675	1160	1710	2315	93	130	170	315	618	1125	1760	2910	2910	RF/RTJ

Standards

Design and Manufacture: ASME B16.34
 Inspection and Test: API 598
 End flange dimension: ASME B16.5, ASME B16.47 A
 BW end dimension: ASME B16.25
 Face to face and end to end: ASME B16.10
 (Check valve/Globe valve)
 Pressure-temperature ratings: ASME B16.34

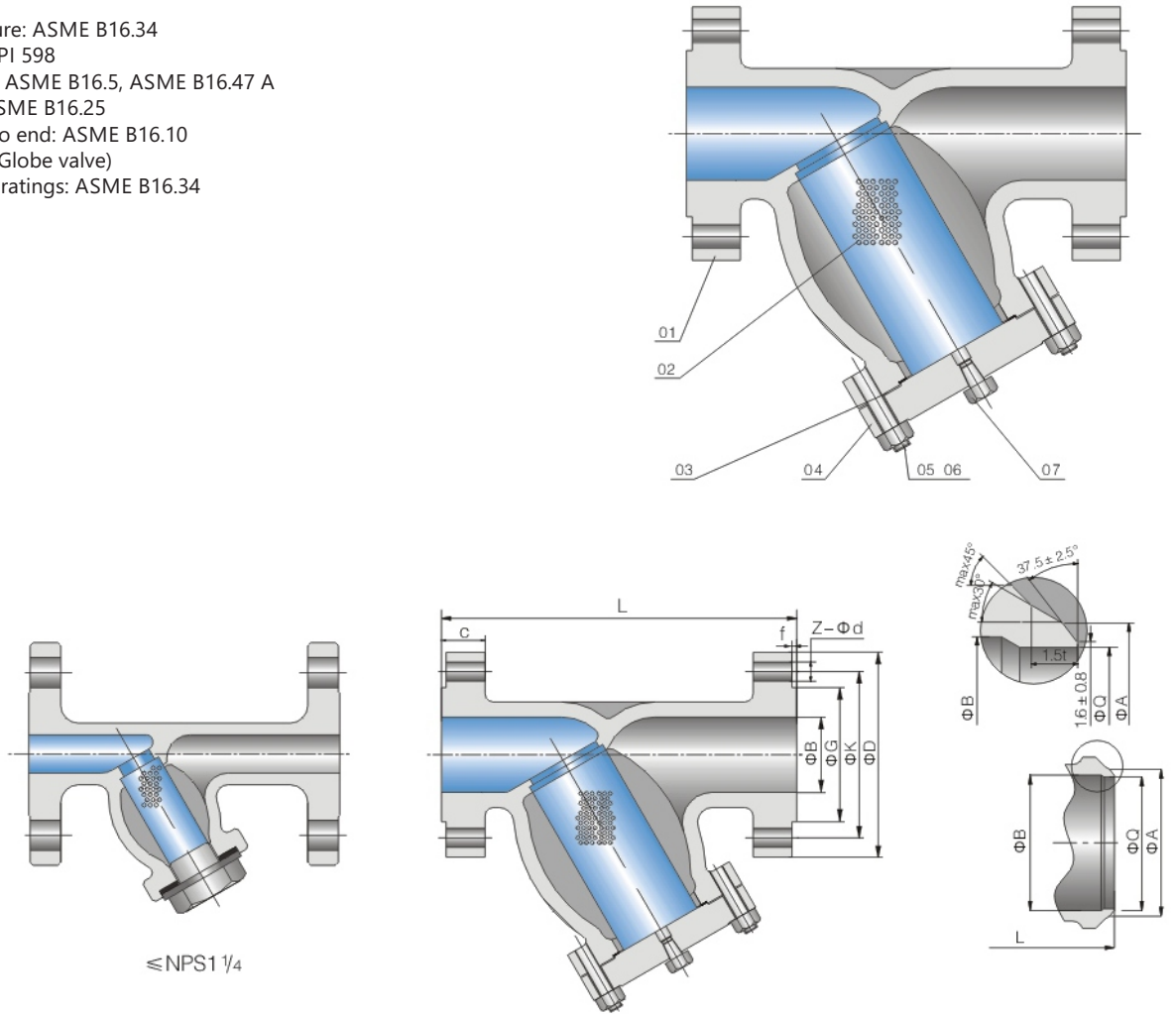

Main parts and material list

No	Parts Name	Material				
		ASTMA216 WCB	ASTMA351 CF8	ASTMA351 CF3	ASTMA351 CF8M	ASTMA351 CF3M
01	Body	ASTMA216 WCB	ASTMA351 CF8	ASTMA351 CF3	ASTMA351 CF8M	ASTMA351 CF3M
02	Screen	SS304	SS304	SS304L	SS316	SS316L
03	Gasket	Graphite Or Graphite+Stainless Steel (304, 304L, 316, 316L)				
04	Cover	A105	A82 F304	A82 F304L	A82 F316	A82 F316L
05	Cover Bolt	A193 B7	A193 B8	A193 B8	A193 B8M	A193 B8M
06	Cover Nut	A194 2H	A194 8	A194 8	A194 8M	A194 8
07	Drainplug	CS	304	304L	316	316L

Note: The chart above only out lists some common composition of strainer parts. We may provide other different parts maerial composition according to the customer's request or the actual valve working condition.

Connection Dimension

Class	Size		Dimensions(mm)										
	NPS	DN	L		B	D	G	f	K	Z-Ød	C	A	Q
			RF	BW									
150Lb	1/2	15	108	--	13	89	35.1	1.6	60.3	4-15.9	9.7	--	Asper client's requirement
	3/4	20	117	--	19	99	42.9	1.6	69.9	4-15.9	10.4	--	
	1	25	127	127	25	108	50.8	1.6	79.3	4-15.9	11.2	35	
	1¼	32	140	140	32	117	63.5	1.6	88.9	4-15.9	12.7	45	
	1½	40	165	165	38	127	73.2	1.6	98.6	4-15.9	14.2	52	
	2	50	203	203	49	152	91.9	1.6	120.7	4-19.1	15.8	63	
	2½	65	216	216	62	178	104.6	1.6	139.7	4-19.1	17.5	75	
	3	80	241	241	74	191	127	1.6	152.4	4-19.1	19.1	91	
	4	100	292	292	100	229	157.2	1.6	190.5	8-19.1	23.9	117	
	6	150	406	406	150	279	215.9	1.6	241.3	8-22.2	25.4	172	
	8	200	495	495	201	343	269.7	1.6	298.5	8-22.2	28.4	223	
	10	250	622	622	252	406	323.9	1.6	362	12-25.4	30.2	278	
	12	300	699	699	303	483	381	1.6	431.8	12-25.4	31.8	329	
	14	350	787	787	334	533	412.8	1.6	476.2	12-28.6	35.1	362	
	16	400	864	864	385	597	469.9	1.6	539.8	16-28.6	36.6	413	
	18	450	978	978	436	635	533.4	1.6	577.9	16-31.8	39.6	464	
	20	500	978	978	487	699	584.2	1.6	635	20-31.8	42.9	516	
	24	600	1295	1295	589	813	692.2	1.6	749.3	20-34.9	47.8	619	
26	650	1295	1295	633	870	749.3	1.6	806.5	24-34.9	68.3	670		
28	700	1448	1448	684	927	800.1	1.6	863.6	28-34.9	71.4	721		
30	750	1524	1524	735	984	857.3	1.6	914.4	28-34.9	74.7	772		
36	900	1965	1965	874	1168	1022.4	1.6	1085.9	32-41.3	90.4	927		

Main Connection Dimension

Class	Size		Dimensions(mm)															
	NPS	DN	L			B	D	G	f	K	Z-Ød	C	RTJ				A	Q
			RF	RTJ	BW								Y	P	E	F		
300Lb	1/2	15	152	164	--	13	95	35.1	1.6	66.5	4-15.9	14.2	51	34.14	--	7.14	--	Asper client's requirement
	3/4	20	178	191	--	19	117	42.9	1.6	82.6	4-19.1	15.7	63.5	42.88	5.56	8.74	--	
	1	25	203	216	203	25	124	50.8	1.6	88.9	4-19.1	17.5	70	50.8	6.35	8.74	--	
	1¼	32	216	229	216	32	133	63.5	1.6	98.6	4-19.1	19.1	79.5	60.32	6.35	8.74	35	
	1½	40	229	241	229	38	155	73.2	1.6	114.3	4-22.2	20.6	90.5	68.27	6.35	8.74	45	
	2	50	267	283	267	49	165	91.9	1.6	127	8-19.1	22.4	108	82.55	6.35	11.91	52	
	2½	65	292	308	292	62	191	104.6	1.6	149.2	8-22.2	25.4	127	101.6	7.92	11.91	63	
	3	80	318	333	318	74	210	127	1.6	168.3	8-22.2	28.4	146	123.82	7.92	11.91	75	
	4	100	356	371	356	100	254	157.2	1.6	200.2	8-22.2	31.8	175	149.22	7.92	11.91	91	
	6	150	445	460	445	150	318	215.9	1.6	269.8	12-22.2	36.6	241	211.12	7.92	11.91	117	
	8	200	533	549	533	201	381	269.7	1.6	330.2	12-25.4	41.1	302	269.88	7.92	11.91	172	
	10	250	622	638	622	252	445	323.9	1.6	387.4	16-28.6	47.8	356	323.85	7.92	11.91	223	
	12	300	711	727	711	303	521	381	1.6	450.9	16-31.8	50.8	413	381	7.92	11.91	278	
	14	350	838	854	838	334	584	412.8	1.6	514.4	20-31.8	53.8	457	419.1	7.92	11.91	329	
	16	400	864	879	864	385	648	469.9	1.6	571.5	20-34.9	57.2	508	469.9	7.92	11.91	362	
	18	450	978	994	978	436	711	533.4	1.6	628.7	24-34.9	60.5	575	533.4	7.92	11.91	413	
	20	500	1016	1035	1016	487	775	584.2	1.6	685.8	24-34.9	63.5	635	584.2	7.92	13.49	464	
	24	600	1346	1368	1346	589	914	692.2	1.6	812.8	28-41.3	69.9	749	692.15	9.52	16.66	516	
26	650	1346	1372	1346	633	972	749.3	1.6	876.3	28-44.5	79.2	809.8	749.3	11.3	19.84	619		
28	700	1499	1524	1499	684	1035	800.1	1.6	939.8	28-44.5	85.9	860.6	800.1	12.7	19.84	670		
30	750	1594	1619	1594	735	1092	857.3	1.6	997	28-47.6	91.9	917.4	857.25	12.7	19.84	721		
36	900	2083	2112	2083	874	1270	1022.4	1.6	1168.4	32-54	104.6	1092.2	1022.35	12.7	23.01	772		

Connection Dimension

Class	Size		Dimensions(mm)															
	NPS	DN	L			B	D	G	f	K	Z-Ød	C	RTJ				A	Q
			RF	RTJ	BW								Y	P	E	F		
600Lb	2	50	292	295	292	49	165	91.9	6.4	127	8-19.1	25.4	108	82.55	7.92	11.91	63	Asper client's requirement
	2½	65	330	333	330	62	191	104.6	6.4	149.2	8-22.2	28.4	127	101.6	7.92	11.91	75	
	3	80	356	359	356	74	210	127	6.4	168.3	8-22.2	31.8	146	123.82	7.92	11.91	91	
	4	100	432	435	432	100	273	157.2	6.4	215.9	8-25.4	38.1	175	149.22	7.92	11.91	117	
	6	150	559	562	559	150	356	215.9	6.4	292.1	12-28.6	47.8	241	211.12	7.92	11.91	172	
	8	200	660	664	660	201	419	269.7	6.4	349.2	12-31.8	55.6	302	269.88	7.92	11.91	223	
	10	250	787	791	787	252	508	323.9	6.4	431.8	16-34.9	63.5	356	323.85	7.92	11.91	278	
	12	300	838	841	838	303	559	381	6.4	489	20-34.9	66.5	413	381	7.92	11.91	329	
	14	350	889	892	889	334	603	412.8	6.4	527.1	20-38.1	69.9	457	419.1	7.92	11.91	362	
	16	400	991	994	991	385	686	469.9	6.4	603.2	20-41.3	76.2	508	469.9	7.92	11.91	413	
	18	450	1092	1095	1092	436	743	533.4	6.4	654.1	20-44.5	82.6	575	533.4	7.92	11.91	464	
	20	500	1194	1200	1194	487	813	587.2	6.4	723.9	24-44.5	88.9	635	584.2	9.52	13.49	516	
	24	600	1397	1407	1397	589	940	692.2	6.4	838.2	24-50.8	101.6	749	692.15	11.3	16.66	619	
	26	650	1448	1461	1448	633	1016	749.3	6.4	914.4	28-50.8	108	809.8	749.3	12.7	19.84	670	
	28	700	1600	1613	1600	684	1073	800.1	6.4	965.2	28-54	111.3	860.6	800.1	12.7	19.84	721	
30	750	1651	1664	1651	735	1130	857.3	6.4	1022.4	28-54	114.3	917.4	857.25	12.7	19.84	772		
36	900	2083	2099	2083	874	1314	1022.4	6.4	1193.8	28-66.7	124	1092.2	1022.35	14.27	23.01	927		

Main Connection Dimension

Class	Size		Dimensions(mm)															
	NPS	DN	L			B	D	G	f	K	Z-Ød	C	RTJ				A	Q
			RF	RTJ	BW								Y	P	E	F		
900Lb	2	50	368	371	368	49	216	91.9	6.4	165.1	8-25.4	38.1	124	95.25	7.92	11.91	63	Asper client's requirement
	2½	65	419	422	419	62	244	104.6	6.4	190.5	8-28.6	41.1	137	107.95	7.92	11.91	75	
	3	80	381	384	381	74	241	127	6.4	190.5	8-25.4	38.1	156	123.82	7.92	11.91	91	
	4	100	457	460	457	100	292	157.2	6.4	235	8-31.8	44.5	181	149.22	7.92	11.91	117	
	6	150	610	613	610	150	381	215.9	6.4	317.5	12-31.8	55.6	241	211.12	7.92	11.91	172	
	8	200	737	740	737	201	470	269.7	6.4	393.7	12-38.1	63.5	308	269.88	7.92	11.91	223	
	10	250	838	841	838	252	546	323.9	6.4	469.9	16-38.1	69.9	362	323.85	7.92	11.91	278	
	12	300	965	968	965	303	610	381	6.4	533.4	20-38.1	79.2	419	381	7.92	11.91	329	
	14	350	1026	1038	1029	322	641	412.8	6.4	558.8	20-41.3	85.9	467	419.1	11.13	16.66	362	
	16	400	1130	1140	1130	373	705	469.9	6.4	616	20-44.5	88.9	524	469.9	11.13	16.66	413	
	18	450	1219	1232	1219	423	787	533.4	6.4	685.8	20-50.8	101.6	594	533.4	12.7	19.84	464	
	20	500	1321	1334	1321	471	857	584.2	6.4	749.3	20-54	108	648	584.2	12.7	19.84	516	
1500Lb	2	50	368	371	368	49	216	91.9	6.4	165.1	8-25.4	38.1	124	95.25	7.92	11.91	63	Asper client's requirement
	2½	65	419	422	419	62	244	104.6	6.4	190.5	8-28.6	41.1	137	107.95	7.92	11.91	75	
	3	80	470	473	470	74	267	127	6.4	203.2	8-31.8	47.8	168	136.52	7.92	11.91	91	
	4	100	546	549	546	100	311	157.2	6.4	241.3	8-34.9	53.8	194	161.92	7.92	11.91	117	
	6	150	705	711	705	144	394	215.9	6.4	317.5	12-38.1	82.6	248	211.12	9.52	13.49	172	
	8	200	832	841	832	192	483	269.7	6.4	393.7	12-44.5	91.9	318	269.88	11.13	16.66	223	
	10	250	991	1000	991	239	584	323.9	6.4	482.6	12-50.8	108	371	323.85	11.13	16.66	278	
	12	300	1130	1146	1130	287	673	381	6.4	571.5	16-54	124	438	381	14.27	23.01	329	
	14	350	1257	1276	1257	315	749	412.8	6.4	635	16-60.3	133.4	489	419.1	15.88	26.97	362	
	16	400	1384	1407	1384	360	826	469.9	6.4	704.9	16-66.7	146.1	546	469.9	17.48	30.18	413	
	18	450	1537	1559	1537	406	914	533.4	6.4	774.7	16-73	162.1	613	533.4	17.48	30.18	464	
	20	500	1664	1686	1664	454	984	584.2	6.4	831.9	16-79.4	177.8	673	584.2	17.48	33.32	516	
24	600	1943	1972	1943	546	1168	692.2	6.4	990.6	16-92	203.2	794	692.15	20.62	36.53	619		

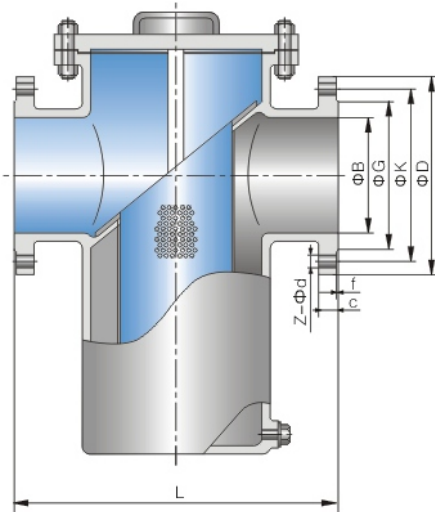

Main Connection Dimension

Class	Size		Dimensions(mm)									
	NPS	DN	L	B	D	G	f	K	Z-Ød	C	Ø	H
150Lb	1/2	15	203	13	89	35.1	1.6	60.3	4-15.9	39.7	118	120
	3/4	20	203	19	99	42.9	1.6	69.9	4-15.9	10.4	118	120
	1	25	203	25	108	50.8	1.6	79.3	4-15.9	11.2	118	120
	1¼	32	203	32	117	63.5	1.6	88.9	4-15.9	12.7	118	130
	1½	40	203	38	127	73.2	1.6	98.6	4-15.9	14.2	118	130
	2	50	203	49	152	91.9	1.6	120.7	4-19.1	15.8	118	150
	2½	65	216	62	178	104.6	1.6	139.7	4-19.1	17.5	118	180
	3	80	241	74	191	127	1.6	152.4	4-19.1	19.1	140	200
	4	100	292	100	229	157.2	1.6	190.5	8-19.1	23.9	160	240
	6	150	406	150	279	215.9	1.6	241.3	8-22.2	25.4	230	370
	8	200	495	201	343	269.7	1.6	298.5	8-22.2	28.4	292	480
	10	250	622	252	406	323.9	1.6	362	12-25.4	30.2	370	520
	12	300	699	303	483	381	1.6	431.8	12-25.4	31.8	420	580
	14	350	787	334	533	412.8	1.6	476.2	12-28.6	35.1	470	620
	16	400	864	385	597	469.9	1.6	539.8	16-28.6	36.6	530	750
	18	450	978	436	635	533.4	1.6	577.9	16-31.8	39.6	580	780

Main Connection Dimension

Class	Size		Dimensions(mm)									
	NPS	DN	L	B	D	G	f	K	Z-Ød	C	Ø	H
300Lb	1	25	203	25	124	50.8	1.6	88.9	4-19.1	17.5	118	120
	1¼	32	216	32	133	63.5	1.6	98.6	4-19.1	19.1	118	130
	1½	40	229	38	155	73.2	1.6	114.3	4-22.2	20.6	118	130
	2	50	267	49	165	91.9	1.6	127	8-19.1	22.4	118	150
	2½	65	292	62	191	104.6	1.6	149.2	8-22.2	25.4	118	180
	3	80	318	74	210	127	1.6	168.3	8-22.2	28.4	140	200
	4	100	356	100	254	157.2	1.6	200.2	8-22.2	31.8	160	240
	6	150	445	150	318	215.9	1.6	269.8	12-22.2	36.6	230	370
	8	200	559	201	381	269.7	1.6	330.2	12-25.4	41.1	292	480
	10	250	622	252	445	323.9	1.6	387.4	16-28.6	47.8	370	520
	12	300	711	303	521	381	1.6	450.9	16-31.8	50.8	420	580
	14	350	838	334	584	412.8	1.6	514.4	20-31.8	53.8	470	620
	16	400	864	385	648	469.9	1.6	571.5	20-34.9	57.2	530	750
	18	450	978	436	711	533.4	1.6	628.7	24-34.9	60.5	580	780

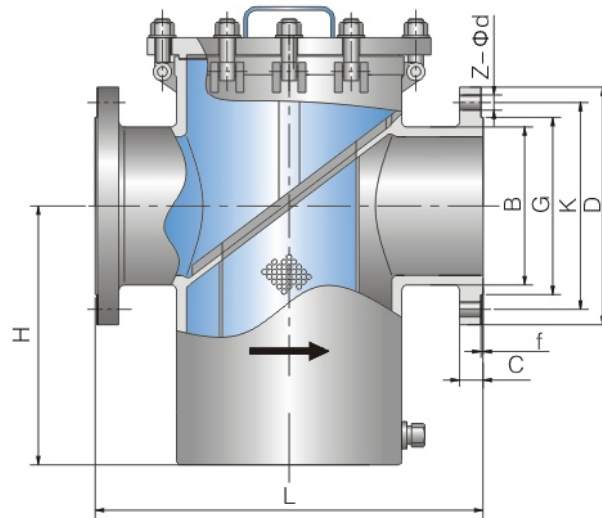

Main Connection Dimension

Class	Size		Dimensions(mm)									
	NPS	DN	L	B	D	G	f	K	Z-Ød	C	Ø	H
150Lb	½	51	203	13	89	35.1	1.6	60.3	4-15.9	39.7	118	120
	¾	20	203	19	99	42.9	1.6	69.9	4-15.9	10.4	118	120
	1	25	203	25	108	50.8	1.6	79.3	4-15.9	11.2	118	120
	1¼	32	203	32	117	63.5	1.6	88.9	4-15.9	12.7	118	130
	1½	40	203	38	127	73.2	1.6	98.6	4-15.9	14.2	118	130
	2	50	203	49	152	91.9	1.6	120.7	4-19.1	15.8	118	150
	2½	65	216	62	178	104.6	1.6	139.7	4-19.1	17.5	118	180
	3	80	241	74	191	127	1.6	152.4	4-19.1	19.1	140	200
	4	100	292	100	229	157.2	1.6	190.5	8-19.1	23.9	160	240
	6	150	406	150	279	215.9	1.6	241.3	8-22.2	25.4	230	370
	8	200	495	201	343	269.7	1.6	298.5	8-22.2	28.4	292	480
	10	250	622	252	406	323.9	1.6	362	12-25.4	30.2	370	520
	12	300	699	303	483	381	1.6	431.8	12-25.4	31.8	420	580
	14	350	787	334	533	412.8	1.6	476.2	12-28.6	35.1	470	620
	16	400	864	385	597	469.9	1.6	539.8	16-28.6	36.6	530	750
18	450	978	436	635	533.4	1.6	577.9	16-31.8	39.6	580	780	

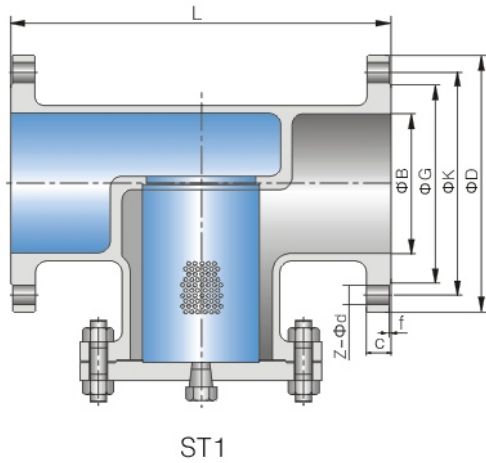

Main Connection Dimension

Class	Size		Dimensions(mm)						
	NPS	DN	L	D	G	f	K	Z-Ød	C
150Lb	2	50	203	152	91.9	1.6	120.7	4-19.1	15.8
	2½	65	216	178	104.6	1.6	139.7	4-19.1	17.5
	3	80	241	191	127	1.6	152.4	4-19.1	19.1
	4	100	292	229	157.2	1.6	190.5	8-19.1	23.9
	6	150	406	279	215.9	1.6	241.3	8-22.2	25.4
	8	200	495	343	269.7	1.6	298.5	8-22.2	28.4
	10	250	622	406	323.9	1.6	362	12-25.4	30.2
	12	300	699	483	381	1.6	431.8	12-25.4	31.8
	14	350	787	533	412.8	1.6	476.2	12-28.6	35.1
	16	400	864	597	469.9	1.6	539.8	16-28.6	36.6
	18	450	978	635	533.4	1.6	577.9	16-31.8	39.6
	20	500	978	699	584.2	1.6	635	20-31.8	42.9
	24	600	1295	813	692.2	1.6	749.3	20-34.9	47.8
	26	650	1295	870	749.3	1.6	806.5	24-34.9	68.3
	28	700	1448	927	800.1	1.6	863.6	28-34.9	71.4
	30	750	1524	984	857.3	1.6	914.4	28-34.9	74.7
	36	900	1965	1168	1022.4	1.6	1085.9	32-41.3	90.4

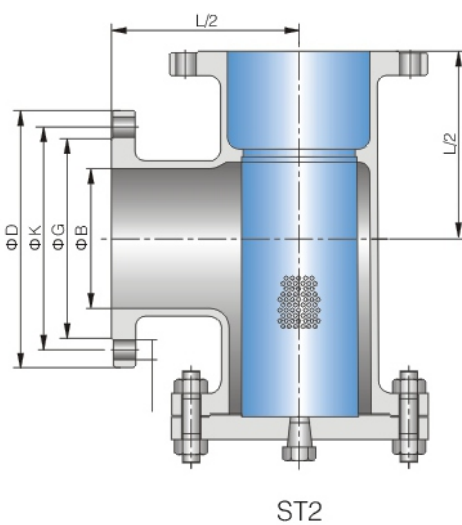

Main Connection Dimension

Class	Size		Dimensions(mm)						
	NPS	DN	L	D	G	f	K	Z-Ød	C
300Lb	2	50	267	165	91.9	1.6	127	8-19.1	22.4
	2½	65	292	191	104.6	1.6	149.2	8-22.2	25.4
	3	80	318	210	127	1.6	168.3	8-22.2	28.4
	4	100	356	254	157.2	1.6	200.2	8-22.2	31.8
	6	150	445	318	215.9	1.6	269.8	12-22.2	36.6
	8	200	533	381	269.7	1.6	330.2	12-25.4	41.1
	10	250	622	445	323.9	1.6	387.4	16-28.6	47.8
	12	300	711	521	381	1.6	450.9	16-31.8	50.8
	14	350	838	584	412.8	1.6	514.4	20-31.8	53.8
	16	400	864	648	469.9	1.6	571.5	20-34.9	57.2
	18	450	978	711	533.4	1.6	628.7	24-34.9	60.5
	20	500	1016	775	584.2	1.6	685.8	24-34.9	63.5
	24	600	1346	914	692.2	1.6	812.8	24-41.3	69.9
	26	650	1346	972	749.3	1.6	876.3	28-44.5	79.2
	28	700	1499	1035	800.1	1.6	939.8	28-44.5	85.9
	30	750	1594	1092	857.3	1.6	997	28-47.6	91.9
	36	900	2083	1270	1022.4	1.6	1168.4	32-54	104.6

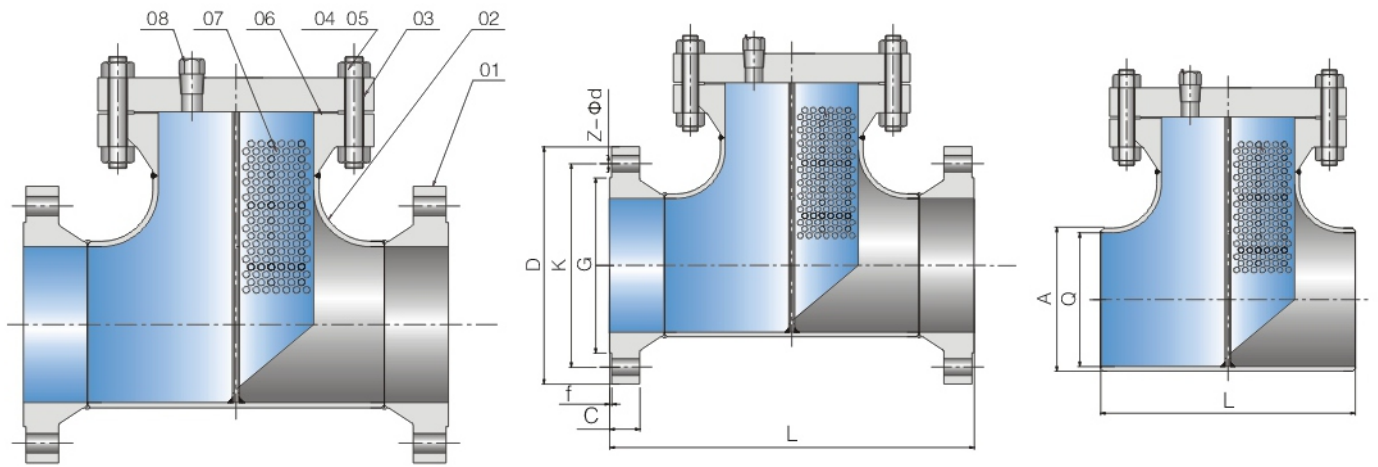

Main Parts and material list

No.	Parts Name	Material				
01	Tee	ASTM A234-WPB	SS304	SS304L	SS316	SS316L
02	Flange	ASTM A105	ASTM A182-F304	ASTM A182-F304L	ASTM A182-F316	ASTM A182-F316L
03	Cover	ASTM A105	ASTM A182-F304	ASTM A182-F304L	ASTM A182-F316	ASTM A182-F316L
04	Cover Bolt	ASTM A193 B7	ASTM A193 B8	ASTM A193 B8	ASTM A193 B8M	ASTM A193 B8M
05	Cover Nut	ASTM A194 2H	ASTM A194 8	ASTM A194 8	ASTM A194 8M	ASTM A194 8M
06	Gasket	Graphite+SS304	Graphite+SS304	Graphite+SS304L	Graphite+SS316	Graphite+SS316L
07	Screen	SS304	SS304	SS304L	SS316	SS316L
08	Drain Plug	ASTM A105	ASTM A182-F304	ASTM A182-F304L	ASTM A182-F316	ASTM A182-F316L

Connection Dimension

Class	Size		Dimensions(mm)										Q
	NPS	DN	L		Flange	D	G	f	K	Z-Ød	C	A	
			RF	BW									
150Lb	2	50	254	117	ANSI/ASME B16.5	152	91.9	1.6	120.7	4-19.1	15.8	60.3	Asper client's requirement
	21/2	65	292	152		178	104.6	1.6	139.7	4-19.1	17.5	73	
	3	80	312	172		191	127	1.6	152.4	4-19.1	19.1	88.9	
	4	100	362	209		229	157.2	1.6	190.5	8-19.1	23.9	114.3	
	6	150	463	285		279	215.9	1.6	241.3	8-22.2	25.4	168.3	
	8	200	559	354		343	269.7	1.6	298.5	8-22.2	28.4	219.1	
	10	250	635	432		406	323.9	1.6	362	12-25.4	30.2	273.1	
	12	300	737	508		483	381	1.6	431.8	12-25.4	31.8	323.9	
	14	350	813	559		533	412.8	1.6	476.2	12-28.6	35.1	355.6	
	16	400	864	609		597	469.9	1.6	539.8	16-28.6	36.6	406.4	
	18	450	965	686		635	533.4	1.6	577.9	16-31.8	39.6	457.2	
	20	500	1051	762		699	584.2	1.6	635	20-31.8	42.9	508	
	22	550	1136	838		749	641	1.6	692	20-34.9	46	558.8	
	24	600	1168	861		813	692.2	1.6	749.3	20-34.9	47.8	609.6	
	26	650	1232	970		870	749.3	1.6	806.5	24-34.9	68.3	660.4	
	28	700	1293	1041		927	800.1	1.6	863.6	28-34.9	71.4	711.2	
	30	750	1391	1117	984	857.3	1.6	914.4	28-34.9	74.7	762		
	32	800	1483	1194	1060	914.4	1.6	977.9	28-41.3	80.8	812.8		
	34	850	1567	1270	1111	965.2	1.6	1028.7	32-41.3	82.6	863.6		
	36	900	1661	1346	1168	1022.4	1.6	1085.9	32-41.3	90.4	914.4		
	38	950	1737	1422	1238	1073.2	1.6	1149.4	32-41.3	87.4	965.2		
	40	1000	1826	1498	1289	1124	1.6	1200.2	36-41.3	90.4	1016		
	42	1020	1867	1524	1346	1193.8	1.6	1257.3	36-41.3	96.8	1066.8		
	44	1100	1982	1625	1403	1244.6	1.6	1314.5	40-41.3	101.6	1117.6		
	46	1150	2074	1701	1454	1295.4	1.6	1365.3	40-41.3	103.1	1168.4		
	48	1200	2162	1778	1511	1358.9	1.6	1422.4	44-41.3	108	1219.2		
	26	650	1169	970	870	749.3	1.6	806.5	24-34.9	68.3	660.4		
	28	700	1232	1041	927	800.1	1.6	863.6	28-34.9	71.4	711.2		
	30	750	1318	1117	987	812.8	1.6	846.1	44-22	44.5	762		
	32	800	1410	1194	1060	914.4	1.6	900.2	48-22	46	812.8		
	34	850	1491	1270	1111	965.2	1.6	957.3	40-26	49.3	863.6		
	36	900	1581	1346	1168	1022.4	1.6	1009.7	44-26	52.3	914.4		
38	950	1671	1422	1238	1073.2	1.6	1069.8	40-28.6	53.8	965.2			
40	1000	1756	1498	1346	1193.8	1.6	1120.6	44-28.6	55.6	1016			
42	1020	1791	1524	1403	1244.6	1.6	1171.4	48-28.6	58.7	1066.8			
44	1100	1889	1625	1454	1358.9	1.6	1222.2	52-28.6	60.5	1117.6			
46	1150	1991	1701	1511	1422.4	1.6	1284.2	40-31.8	62.0	1168.4			
48	1200	2078	1778	1592	1428.1	1.6	1335.0	44-31.8	65.0	1219.2			

Main Connection Dimension

Class	Size		Dimensions(mm)										Q				
	NPS	DN	L			D	G	f	K	Z-Ød	C	RTJ				A	
			RF	RTJ	BW							Y		P	E		F
300Lb	2	50	267	283	117	165	91.9	1.6	127	8-19.1	22.4	108	82.55	7.92	11.91	60.3	Asper client's requirement
	21/2	65	305	321	152	191	104.6	1.6	149.2	8-22.2	25.4	127	101.6	7.92	11.91	73	
	3	80	330	346	172	210	127	1.6	168.3	8-22.2	28.4	146	123.82	7.92	11.91	88.9	
	4	100	381	397	209	254	157.2	1.6	200.2	8-22.2	31.8	175	149.22	7.92	11.91	114.3	
	6	150	483	499	285	318	215.9	1.6	269.8	12-22.2	36.6	241	211.12	7.92	11.91	168.3	
	8	200	578	594	354	381	269.7	1.6	330.2	12-25.4	41.1	302	269.88	7.92	11.91	219.1	
	10	250	666	682	432	445	323.9	1.6	387.4	16-28.6	47.8	356	323.85	7.92	11.91	273.1	
	12	300	768	784	508	521	381	1.6	450.9	16-31.8	50.8	413	381	7.92	11.91	323.9	
	14	350	844	860	559	584	412.8	1.6	514.4	20-31.8	53.8	457	419.1	7.92	11.91	355.6	
	16	400	902	918	609	648	469.9	1.6	571.5	20-34.9	57.2	508	469.9	7.92	11.91	406.4	
	18	450	1004	1020	686	711	533.4	1.6	628.7	24-34.9	60.5	575	533.4	7.92	11.91	457.2	
	20	500	1086	1105	762	775	584.2	1.6	685.8	24-34.9	63.5	635	584.2	9.52	13.49	508	
	24	600	1200	1222	861	914	692.2	1.6	812.8	24-41.3	69.9	749	692.15	11.13	16.66	609.6	
	600Lb	2	50	286	289	117	165	91.9	1.6	127	8-19.1	25.4	108	82.55	7.92	11.91	
21/2		65	324	327	152	191	104.6	1.6	149.2	8-22.2	28.4	127	101.6	7.92	11.91	73	
3		80	350	353	172	210	127	1.6	168.3	8-22.2	31.8	146	123.82	7.92	11.91	88.9	
4		100	425	428	209	273	157.2	1.6	215.9	8-25.4	38.1	175	149.22	7.92	11.91	114.3	
6		150	533	536	285	356	215.9	1.6	292.1	12-28.6	47.8	241	211.12	7.92	11.91	168.3	
8		200	635	638	354	419	269.7	1.6	349.2	12-31.8	55.6	302	269.88	7.92	11.91	219.1	
10		250	750	753	432	508	323.9	1.6	431.8	16-34.9	63.5	356	323.85	7.92	11.91	273.1	
12		300	832	835	508	559	381	1.6	489	20-34.9	66.5	413	381	7.92	11.91	323.9	
14		350	902	905	559	603	412.8	1.6	527.1	20-38.1	69.9	457	419.1	7.92	11.91	355.6	
16		400	978	980	609	686	469.9	1.6	603.2	20-41.3	76.2	508	469.9	7.92	11.91	406.4	
18		450	1067	1070	686	743	533.4	1.6	654.1	20-44.5	82.6	575	533.4	7.92	11.91	457.2	
20		500	1156	1162	762	813	584.2	1.6	723.9	24-44.5	88.9	635	584.2	9.52	13.49	508	
24		600	1283	1293	861	940	692.2	1.6	838.2	24-50.8	101.6	749	692.15	11.13	16.66	609.6	

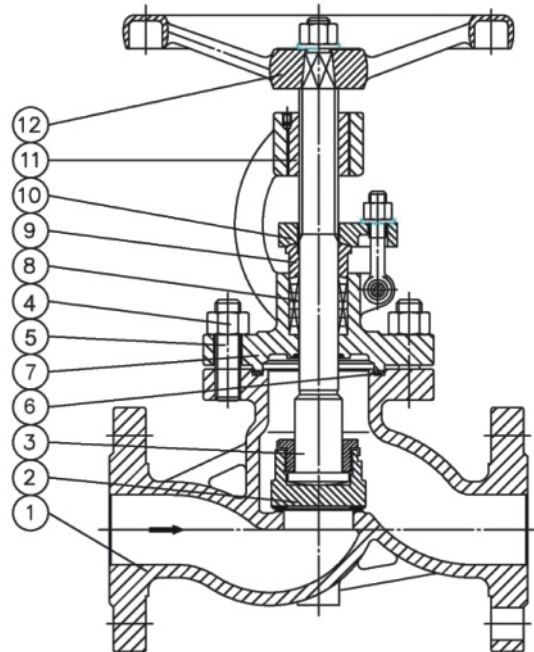

Standards

Design and Manufacture: DIN 3356 EN 13709
 Face to face dimensions: DIN 3202, EN 558
 Flange ENDS dimensions: DIN 2543
 DIN 2544, DIN 2545, DIN 2546
 DIN 2547, DIN 2548, EN 1092-1
 Test & inspect: DN 3230, EN 12266-1

Parts and material list

Part Name	Material				
	Trim 1	Trim 8	Trim 5		
1 Body	DIN 17245 GS-C25+CR13	DIN 17245 GS-C25+STL	DIN 17245 GS-C25+STL	DIN 17445 1.4308	DIN 17445 1.4408
2 Disc	DIN 17245 GS-C25+CR13	DIN 17245 GS-C25+CR13	DIN 17245 GS-C25+STL	DIN 17445 1.4308	DIN 17445 1.4408
7 Bonnet	DIN 17245 GS-C25	DIN 17245 GS-C25	DIN 17245 GS-C25	DIN 17445 1.4308	DIN 17445 1.4408
9 Gland	ASTM A182 F6a			ASTM A182 F304	ASTM A182 F316
10 Gland Flange	DIN 17245 GS-C25			DIN 17445 1.4308	DIN 17445 1.4308
3 Stem	ASTM A182 F6a			ASTM A182 F304	ASTM A182 F316
4 Nut	A194 2H			A194 8	A194 8
5 Bolt	A193 B7			A193 B8	A193 B8
6 Gasket	SS Spiral wound W/graphite, or SS Spiral wound W/PTFE, or Reinforced PTFE				
8 Packing	Braided graphite or reformed graphite ring or PTFE				
11 Stem Nut	Copper alloy or A439 D2				
12 Hand Wheel	Ductile iron or carbon steel				

Noted: The chart above only lists out some common composition of steel globe valve parts. We may provided other different parts material composition according to the customer's request or the actual valve working condition.

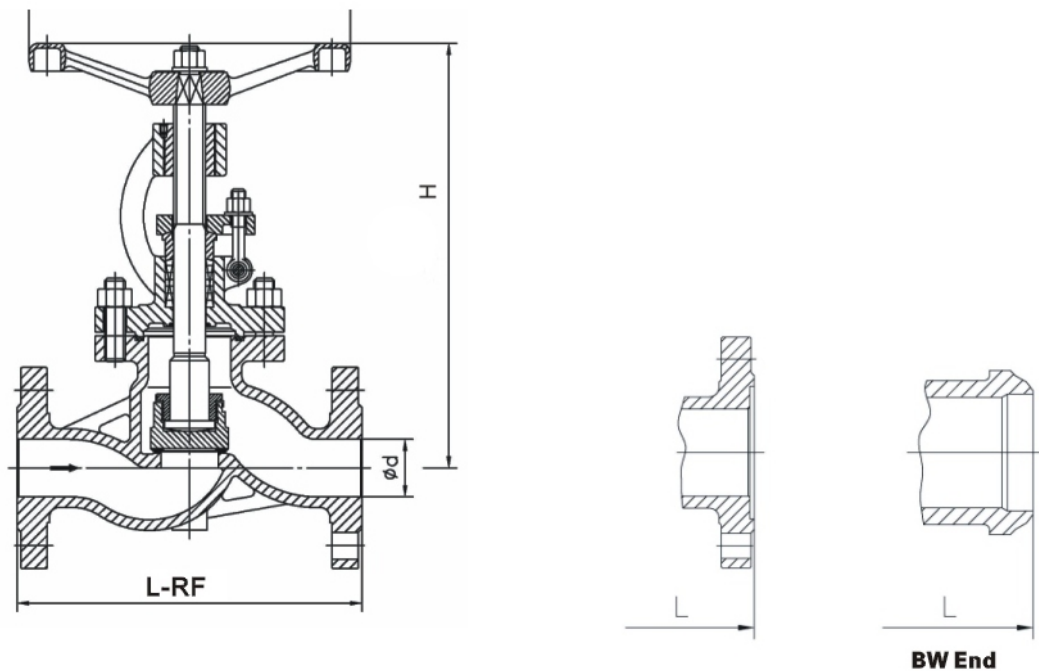

Dimensions

PN16(DIN 3202-F1)

DN(mm)	15	20	25	32	40	50	65	80	100	125	150	200	250	300	350	400	450	500
L-RF(mm)	130	150	160	180	200	230	290	310	350	400	480	600	730	850	980	1100	1200	1250
L-BW(mm)	130	150	160	180	200	230	290	310	350	400	480	600	730	850	980	1100	1200	1250
H(mm)	190	210	235	235	285	310	340	370	420	480	510	610	770	890	--	--	--	--
W(kg)	120	140	160	180	200	200	250	280	300	360	400	400	450	500	--	++	--	--

PN25(DIN 3202-F1)

DN(mm)	15	20	25	32	40	50	65	80	100	125	150	200	250	300	350	400	--	--
L-RF(mm)	130	150	160	180	200	230	290	310	350	400	480	600	730	850	980	1100	--	--
L-BW(mm)	130	150	160	180	200	230	290	310	350	400	480	600	730	850	980	1100	--	--
H(mm)	190	210	235	235	285	310	340	370	420	480	535	660	790	940	1010	1125	--	--
W(kg)	120	140	160	180	200	200	250	280	300	360	400	400	450	500	--	--	--	--

PN40(DIN 3202-F1)

DN(mm)	15	20	25	32	40	50	65	80	100	125	150	200	250	300	350	400	--	--
L-RF(mm)	130	150	160	180	200	230	290	310	350	400	480	600	730	850	980	1100	--	--
L-BW(mm)	130	150	160	180	200	230	290	310	350	400	480	600	730	850	980	1100	--	--
H(mm)	190	210	235	235	285	310	340	370	420	480	560	725	815	945	1015	1150	--	--
W(kg)	120	140	160	180	200	200	250	280	300	360	500	500	--	--	--	--	--	--

PN63(DIN 3202-F2)

DN(mm)	15	20	25	32	40	50	65	80	100	125	150	200	250	300	--	--	--	--
L-RF(mm)	210	230	230	260	260	300	340	380	430	500	550	650	775	900	--	--	--	--
L-BW(mm)	210	230	230	260	260	300	340	380	430	500	550	650	775	900	--	--	--	--
W(kg)	210	248	275	355	395	450	494	531	588	650	715	813	--	--	--	--	--	--

PN100(DIN 3202-F2)

DN(mm)	15	20	25	32	40	50	65	80	100	125	150	200	250	300	--	--	--	--
L-RF(mm)	210	230	230	260	260	300	340	380	430	500	550	650	775	900	--	--	--	--
L-BW(mm)	210	230	230	260	260	300	340	380	430	500	550	650	775	900	--	--	--	--
W(kg)	210	248	275	355	395	450	494	531	588	650	715	813	--	--	--	--	--	--

Noted: We may provide other different actuators according to the customer's request, such as pneumatic, electric, hydraulic actuators, the details of them according to the actual valve working condition.

Noted: The face to face dimension of BW-end-valve is the same as that of flanged-end-valve.

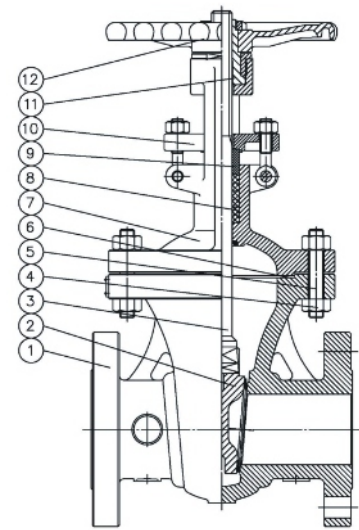

Standards

Design and Manufacture: DIN 3352, BS EN 1984
 Face to face dimensions: DIN 3202, BS EN 558-1
 Flange ENDS dimensions: DIN 2543, EN 1092-1
 DIN 2544, DIN 2545, DIN 2546
 Test & inspect: DN 3230, EN 12266-1

Parts and material list

Part Name	Material					
	Trim 1	Trim 8	Trim 5			
1 Body	DIN 17245 GS-C25+CR13	DIN 17245 GS-C25+STL	DIN 17245 GS-C25+STL	DIN 17445 1.4308	DIN 17445 1.4408	
2 Wedge	DIN 17245 GS-C25+CR13	DIN 17245 GS-C25+CR13	DIN 17245 GS-C25+STL	DIN 17445 1.4308	DIN 17445 1.4408	
7 Bonnet	DIN 17245 GS-C25	DIN 17245 GS-C25	DIN 17245 GS-C25	DIN 17445 1.4308	DIN 17445 1.4408	
9 Gland	ASTM A182 F6a			ASTM A182 F304	ASTM A182 F316	
10 Gland Flange	DIN 17245 GS-C25			DIN 17445 1.4308	DIN 17445 1.4308	
3 Stem	ASTM A182 F6a			ASTM A182 F304	ASTM A182 F316	
4 Nut	A194 2H			A194 8	A194 8	
5 Bolt	A193 B7			A193 B8	A193 B8	
6 Gasket	SS Spiral wound W/graphite, or SS Spiral wound W/PTFE, or Reinforced PTFE					
8 Packing	Braided graphite or reformed graphite ring or PTFE					
11 Stem Nut	Copper alloy or A439 D2					
12 Hand Wheel	Ductile iron or carbon steel					

Noted: The chart above only list out some common composition of steel gate valve parts. We may provide other different parts material composition according to the customer's request or the actual valve working condition.

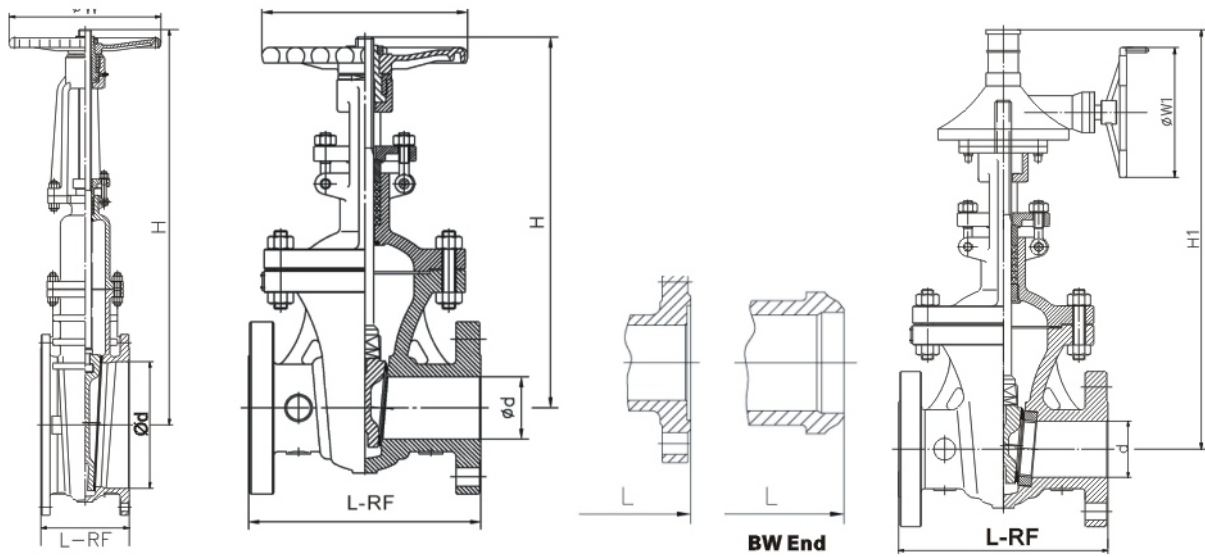

Dimensions

PN10(DIN 3202-F4)

DN(mm)	25	32	40	50	65	80	100	125	150	200	250	300	350	400	450	500	600	700	800	900	1000	1200
L-RF(mm)	--	130	140	150	170	180	190	200	210	230	250	270	290	310	330	350	390	430	470	510	550	630
H ₁ (mm)	--	268	295	305	345	370	445	530	565	725	885	1010	1140	1295	1380	1535	1835	2155	--	--	--	--
H(mm)	--	--	--	--	--	--	--	--	--	965	1220	1365	1545	1755	1890	2085	2435	2925	3275	3670	4220	4845
W(mm)	--	180	200	200	200	250	280	280	300	360	400	400	450	500	500	600	700	800	--	--	--	--
W ₁ (mm)	--	--	--	--	--	--	--	--	--	310	310	310	310	460	460	460	460	530	530	530	530	600
W(kg)	--	10	13	18	23	29	38	53	68	108	160	220	275	390	487	563	852	1250	1830	2295	3700	5050

PN16(DIN 3202-F5)

DN(mm)	25	32	40	50	65	80	100	125	150	200	250	300	350	400	450	500	600	700	800	900	1000	1200
L-RF(mm)	160	180	240	250	270	280	300	325	350	400	450	500	550	600	650	700	800	900	1000	1100	1200	1400
H ₁ (mm)	205	270	305	325	350	415	465	545	610	775	905	1020	1180	1300	1420	1585	1810	--	--	--	--	--
H(mm)	--	--	--	--	--	--	--	--	--	1220	1370	1525	1755	1890	2135	2585	2945	3345	3750	4005	4830	--
W(mm)	160	180	200	200	200	250	280	300	360	360	400	450	500	500	600	600	680	--	--	--	--	--
W ₁ (mm)	--	--	--	--	--	--	--	--	--	310	310	310	460	460	460	600	600	600	600	600	600	600
W(kg)	10	15	18	23	25	38	45	72	97	169	258	330	470	572	816	1180	1450	1860	2461	3080	3944	6020

PN25(DIN 3202-F5)

DN(mm)	25	32	40	50	65	80	100	125	150	200	250	300	350	400	450	500	600	700	800	900	1000	1200
L-RF(mm)	160	180	240	250	270	280	300	325	350	400	450	500	550	600	650	700	800	900	1000	1100	1200	1400
H ₁ (mm)	205	270	305	325	350	415	465	545	610	775	905	1020	1180	1300	1420	1585	1810	--	--	--	--	--
H(mm)	--	--	--	--	--	--	--	--	--	1220	1370	1525	1755	1890	2135	2585	2945	3345	3750	4005	4830	--
W(mm)	160	180	200	200	250	250	250	280	300	350	400	450	500	500	600	600	700	--	--	--	--	--
W ₁ (mm)	--	--	--	--	--	--	--	--	--	310	310	310	460	460	460	600	600	600	600	600	600	600
W(kg)	11	16	18	25	30	42	56	76	108	182	280	352	495	652	925	1250	1560	2030	2558	3870	4960	7558

PN40(DIN 3202-F7)

DN(mm)	25	32	40	50	65	80	100	125	150	200	250	300	350	400	500	600	700	800	900	--	--	--
L-RF(mm)	160	180	240	250	270	310	350	400	450	550	650	750	850	950	1150	1350	1550	1750	1950	--	--	--
H ₁ (mm)	210	270	323	377	389	418	489	541	630	824	915	1085	1190	1310	1560	1875	--	--	--	--	--	--
H(mm)	--	--	--	--	--	--	--	--	--	1225	1420	1580	1755	2125	2520	2945	3450	3890	--	--	--	--
W(mm)	160	180	200	200	250	250	300	300	360	400	450	500	600	600	650	750	--	--	--	--	--	--
W ₁ (mm)	--	--	--	--	--	--	--	--	--	310	310	310	460	530	530	600	600	600	--	--	--	--
W(kg)	11	16	18	25	33	45	59	78	116	225	360	513	710	955	1368	2150	3050	--	--	--	--	--

Noted: We may provide other different actuators according to the customer's request, such as pneumatic, electric, hydraulic actuators, the details of them according to the actual valve working condition.

Noted: For DN≤40, the face to face dimension conform to the F1 series

Noted: The face to face dimension of BW-end-valve is the same as that of flanged-end-valve.

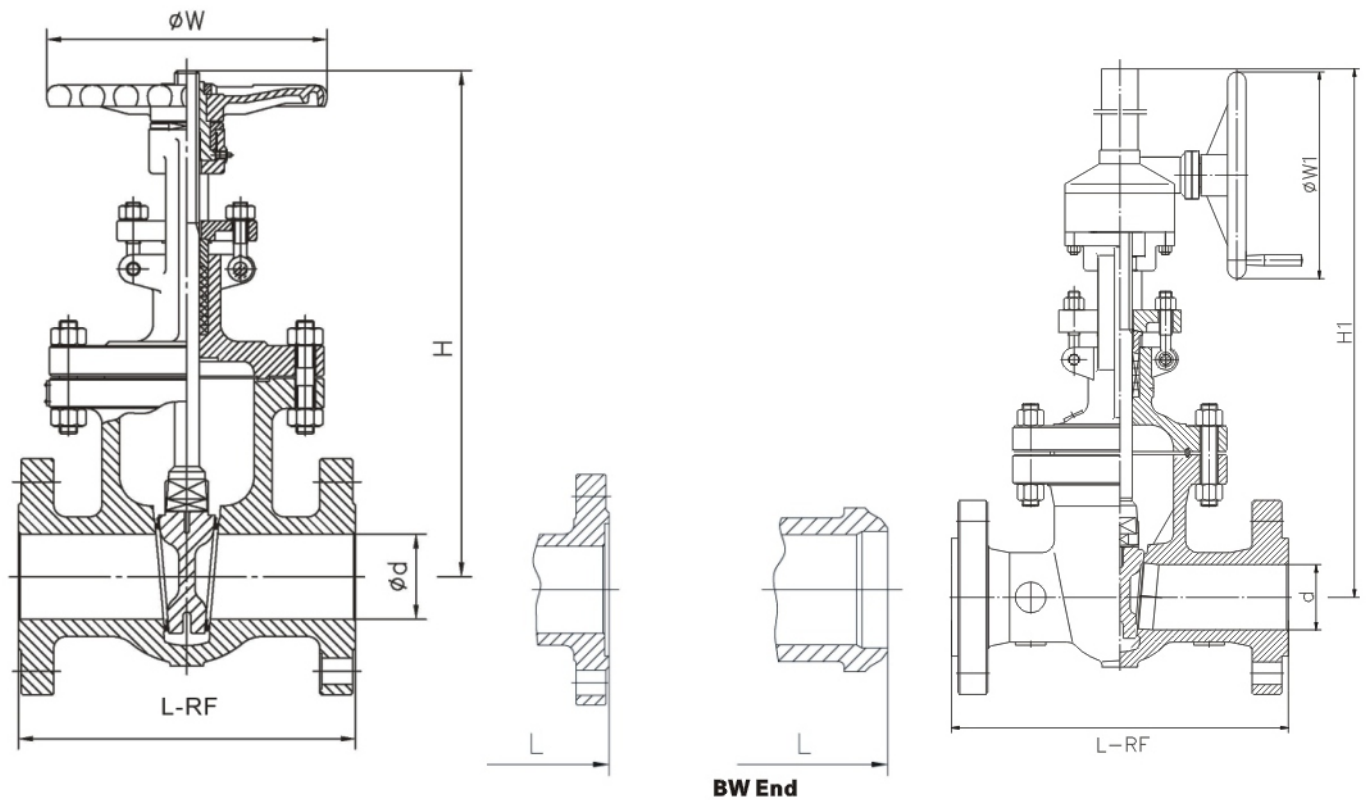

Dimensions

PN63(DIN 3202-F7)

DN(mm)	40	50	65	80	100	125	150	200	250	300	350	400	500	600
L-RF(mm)	240	250	290	310	350	400	450	550	650	750	850	950	1150	1350
H ₁ (mm)	323	380	410	450	525	605	675	820	975	1115	1235	1385	1500	1690
H(mm)	--	--	--	--	--	--	890	1080	1285	1475	1635	1840	2180	2500
W(mm)	180	200	250	250	300	300	360	400	450	500	600	600	--	--
W ₁ (mm)	--	--	--	--	--	--	310	310	460	460	460	530	530	530
W(kg)	22	32	39	53	78	123	176	340	435	560	843	1310	1900	3765

PN100(DIN 3202-F7)

DN(mm)	40	50	65	80	100	125	150	200	250	300	350	400	500	600
L-RF(mm)	240	250	290	310	350	400	450	550	650	750	850	950	1150	1350
H ₁ (mm)	360	390	415	460	510	625	750	890	1050	1208	--	--	--	--
H(mm)	--	--	--	--	--	--	890	1200	1415	1680	1900	2285	--	--
W(mm)	180	200	250	280	300	360	450	500	650	700	--	--	--	--
W ₁ (mm)	--	--	--	--	--	--	310	310	460	460	460	530	--	--
W(kg)	28	42	55	63	101	147	228	449	608	1020	1350	1650	--	--

PN160(DIN 3202-F8)

DN(mm)	40	50	65	80	100	125	150	200	250	300	--	--	--	--
L-RF(mm)	270	300	360	390	450	525	600	750	900	1050	--	--	--	--
H ₁ (mm)	365	512	560	585	631	670	820	990	--	--	--	--	--	--
H(mm)	--	--	--	--	--	840	955	1235	1500	1725	--	--	--	--
W(mm)	250	28	280	300	360	400	500	650	--	--	--	--	--	--
W ₁ (mm)	--	--	--	--	--	310	310	460	460	530	--	--	--	--
W(kg)	50	74	107	120	180	342	410	582	950	1380	--	--	--	--

Noted: We may provide other different actuators according to the customer's request, such as pneumatic, electric, hydraulic actuators, the details of them according to the actual valve working condition.

Noted: The face to face dimension of BW-end-valve is the same as that of flanged-end-valve.

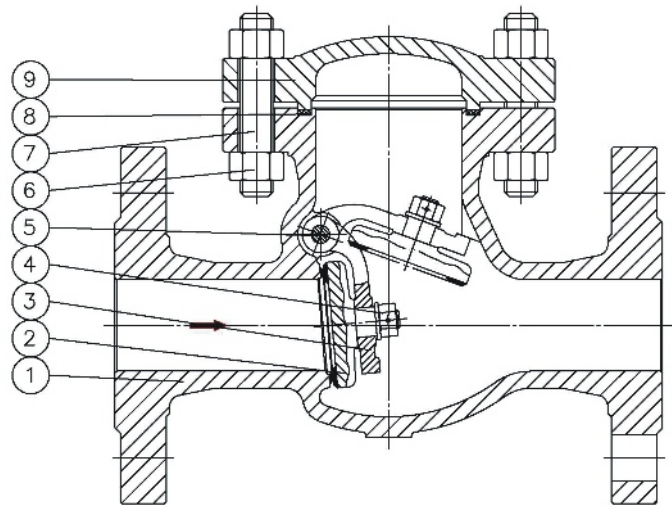

Standards

Design and Manufacture: DIN 3356
 Face to face dimensions: DIN 3202, BS EN 558-1
 Flange ENDS dimensions: DIN 2543, EN 1092-1
 DIN 2544, DIN 2545, DIN 2546, DIN 2548
 Test & inspect: DN 3230, BSEN 12569

Parts and material list

Part Name		Material				
1	Body	DIN 17245 GS-C25+CR13	DIN 17245 GS-C25+STL	DIN 17245 GS-C25+STL	DIN 17445 1.4308	DIN 17445 1.4408
2	Disc	DIN 17245 GS-C25+CR13	DIN 17245 GS-C25+CR13	DIN 17245 GS-C25+STL	DIN 17445 1.4308	DIN 17445 1.4408
9	Cover	DIN 17245 GS-C25	DIN 17245 GS-C25	DIN 17245 GS-C25	DIN 17445 1.4308	DIN 17445 1.4408
3	Arm	DIN 17245 GS-C25	DIN 17245 GS-C25	DIN 17245 GS-C25	DIN 17445 1.4308	DIN 17445 1.4408
5	Pin	ASTM A182 F6a	ASTM A182 F6a	ASTM A182 F6a	ASTM A182 F304	ASTM A182 F304
6	Nut	ASTM A194 2H			ASTM A194 8	ASTM A194 8
7	Bolt	ASTM A194 B7			ASTM A193 B8	ASTM A193 B8
4	Nut	ASTM A194 2H			ASTM A182 F304	ASTM A182 F304
8	Gasket	SS Spiral wound W/graphite, or SS Spiral wound W/PTFE, or Reinforced PTFE				

Noted: The chart above only lists out some common composition of steel check valve parts. We may provide other different parts material composition according to the customer's request or the actual valve working condition.

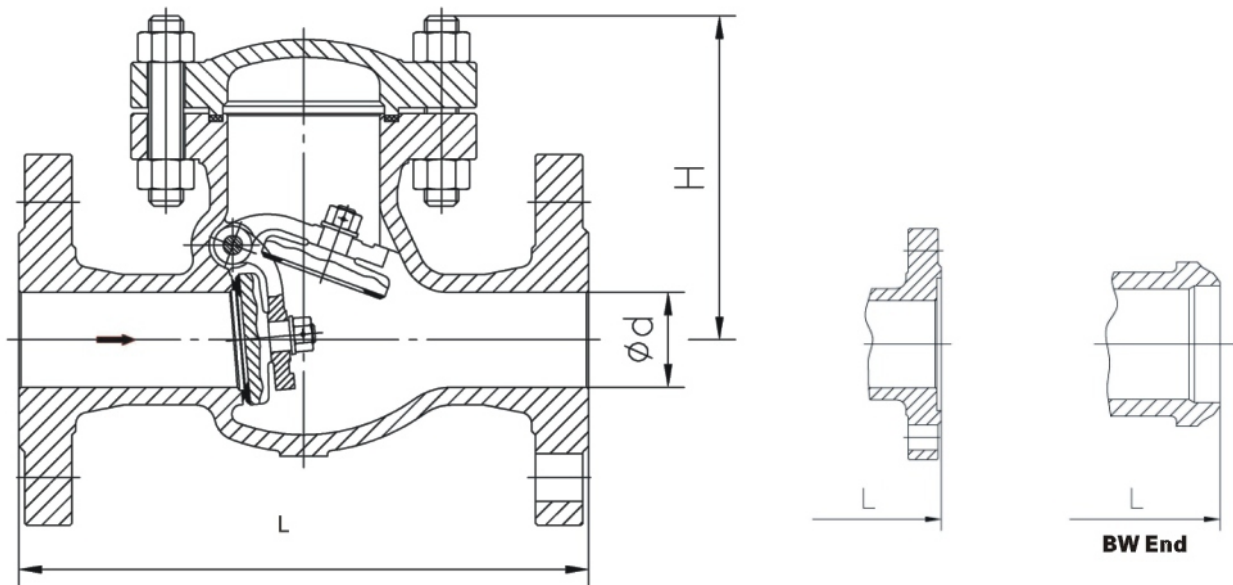

Dimensions

	PN16(DIN 3202-F1)							PN16(DIN 3202-F7)										
DN(mm)	40	50	65	80	100	125	150	200	250	300	350	400	450	500	600	700	800	900
L(mm)	200	230	290	310	350	400	480	550	650	750	850	950	1050	1150	1350	1550	1750	1950
H(mm)	129	147	161	178	190	265	285	345	394	420	455	520	565	610	740	895	1240	1450
W(kg)	13	16	23	31	40	53	80	116	216	316	440	513	582	800	1158	1380	1540	1790

	PN25(DIN 3202-F1)							PN25(DIN 3202-F7)										
DN(mm)	40	50	65	80	100	125	150	200	250	300	350	400	450	500	600	700	800	900
L(mm)	200	230	290	310	350	400	480	550	650	750	850	950	1050	1150	1350	1550	1750	1950
H(mm)	129	147	161	178	190	265	285	345	394	420	455	520	565	610	740	895	1240	1450
W(kg)	14	20	27	44	55	88	145	213	297	375	495	545	600	815	1200	1400	1620	1830

	PN40(DIN 3202-F1)																	
DN(mm)	40	50	65	80	100	125	150	200	250	300	350	400	450	500	600	700	800	900
L(mm)	200	230	290	310	350	400	480	600	730	850	980	1100	1200	1250	1450	1650	1850	2050
H(mm)	135	152	178	185	210	290	310	365	145	480	510	545	595	655	860	--	--	--
W(kg)	15	22	29	40	46	58	92	168	310	430	558	780	915	1170	1350	--	--	--

	PN63(DIN 3202-F2)																	
DN(mm)	40	50	65	80	100	125	150	200	250	300	350	400	450	500	600	--	--	--
L(mm)	260	300	340	380	430	500	550	650	775	900	1025	1150	1275	1400	1600	--	--	--
H(mm)	165	175	192	225	280	308	335	390	452	520	570	626	695	770	905	--	--	--
W(kg)	40	48	62	80	114	187	214	329	418	640	911	1130	1320	1693	2015	--	--	--

	PN100(DIN 3202-F2)																	
DN(mm)	40	50	65	80	100	125	150	200	250	300	350	400	450	500	600	--	--	--
L(mm)	260	300	340	380	430	500	550	650	775	900	1025	1150	1275	1400	1600	--	--	--
H(mm)	165	183	205	236	272	305	345	398	456	528	600	685	--	--	--	--	--	--
W(kg)	48	65	73	87	105	192	208	370	668	963	1100	1358	--	--	--	--	--	--

Noted: The face to face dimension of BW-end-valve is the same as that of flanged-end-valve.

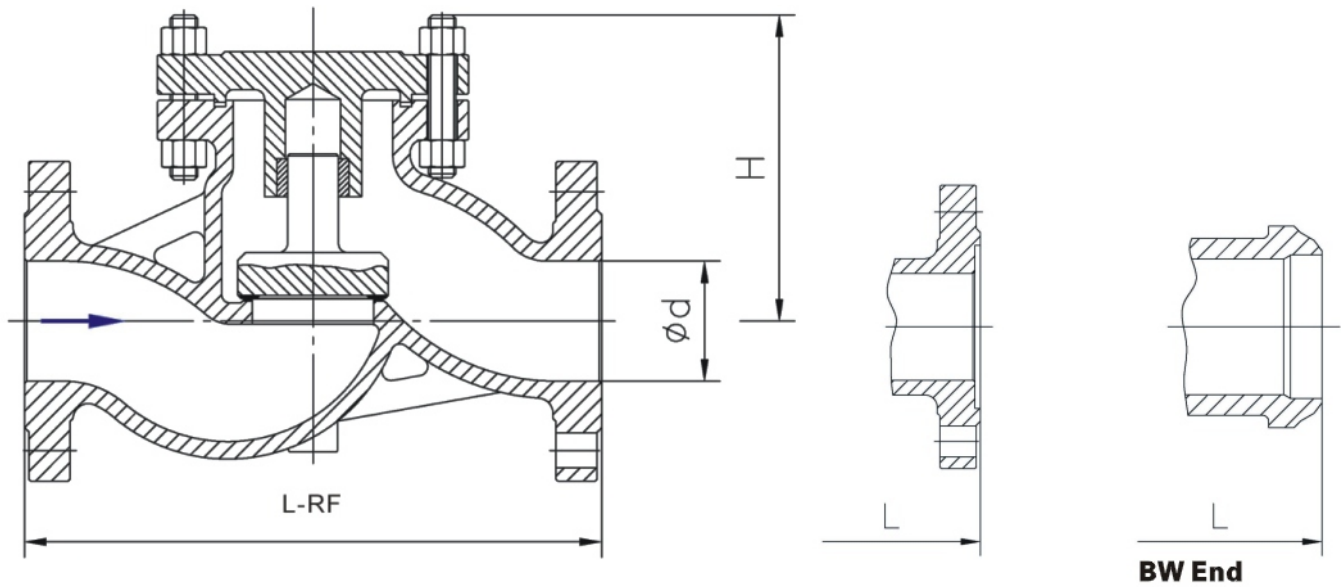

PN16(DIN 3202-F1)																
DN(mm)	15	20	25	32	40	50	65	80	100	125	150	200	250	300	350	400
L(mm)	130	150	160	180	200	230	290	310	350	400	480	600	730	850	980	1100
H(mm)	130	150	160	180	200	230	290	310	350	400	480	600	730	850	980	1100
W(kg)	77	77	80	85	95	105	120	130	140	155	180	215	260	315	--	--

PN25(DIN 3202-F1)																
DN(mm)	15	20	25	32	40	50	65	80	100	125	150	200	250	300	350	400
L(mm)	130	150	160	180	200	230	290	310	350	400	480	600	730	850	980	1100
H(mm)	130	150	160	180	200	230	290	310	350	400	480	600	730	850	980	1100
W(kg)	100	105	120	130	135	149	160	169	194	222	255	305	355	410	--	--

PN40(DIN 3202-F1)																
DN(mm)	15	20	25	32	40	50	65	80	100	125	150	200	250	300	--	--
L(mm)	130	150	160	180	200	230	290	310	350	400	480	600	730	850	--	--
H(mm)	130	150	160	180	200	230	290	310	350	400	480	600	730	850	--	--
W(kg)	100	105	120	130	135	149	160	169	194	225	255	305	360	415	--	--

PN63(DIN 3202-F2)																
DN(mm)	15	20	25	32	40	50	65	80	100	125	150	200	250	300	--	--
L(mm)	210	230	230	260	260	300	340	380	430	500	550	650	775	900	--	--
H(mm)	210	230	230	260	260	300	340	380	430	500	550	650	775	900	--	--
W(kg)	100	110	125	140	168	170	188	205	230	240	265	310	--	--	--	--

PN100(DIN 3202-F2)																
DN(mm)	15	20	25	32	40	50	65	80	100	125	150	200	250	300	--	--
L(mm)	210	230	230	260	260	300	340	380	430	500	550	650	775	900	--	--
H(mm)	210	230	230	260	260	300	340	380	430	500	550	650	775	900	--	--
W(kg)	100	110	125	140	170	185	200	235	265	310	350	400	--	--	--	--

Noted: The face to face dimension of BW-end-valve is the same as that of flanged-end-valve.

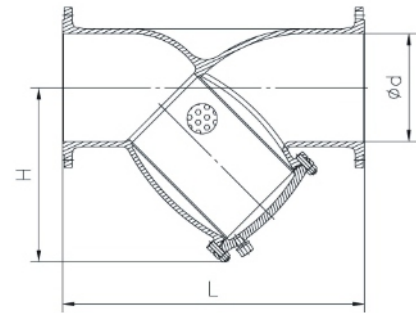
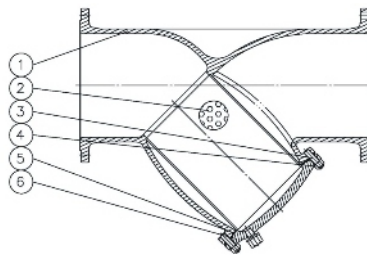

Standards

Design and Manufacture: BS EN 13709
 Face to face dimensions: DIN 3202, BS EN 558-1
 Flange ends dimensions: DIN 2543-2551, BS EN 1092-1
 Test & inspect: DIN 3230, BS EN 12569

Percentage open area

Even the mesh is same open area not always same due to the diameter of wire
 The details of wire as follows

A: Number of wire
 B: Diameter of wire
 C: Width of opening
 D: Percentage of open area

Mesh	A SWG	B(mm)	C(mm)	D(%)
5	20	0.914	4.166	67.3
10	22	0.711	1.829	51.8
20	28	0.356	0.914	51.8
30	32	0.274	0.572	45.7
40	36	0.193	0.442	48.4
50	37	0.172	0.336	43.6
60	38	0.152	0.271	41.0
80	40	0.122	0.195	37.8
100	42	0.102	0.152	35.8
120	43	0.092	0.119	31.8
150	45½	0.066	0.103	37.1
180	46½	0.053	0.088	38.9
200	47	0.051	0.073	35.8
250	48	0.040	0.062	37.7
300	48	0.039	0.044	27.6

Parts and material list

Part Name			Material		
1	Body	DIN 17245 GS-C25	DIN 17445 1.4308	DIN 17445 1.4408	
2	Screen	ASTM 182 F304	ASTM 182 F304	ASTM 182 F316	
3	Bonnet Bolt	ASTM A193 B7	ASTM 193 B8	ASTM 193 B8	
4	Bonnet Nut	ASTM 194 2H	ASTM 194 8	ASTM 194 8	
5	Gasket	Graphite+SS304	Graphite+SS304	Graphite+SS316	
6	Bonnet	DIN 17245 GS-C25	DIN 17445 1.4308	DIN 17445 1.4408	

PN16(DIN 3202-F1)																		
DN(mm)	15	20	25	32	40	50	65	80	100	125	150	200	250	300	350	400	500	600
L(mm)	130	150	160	180	200	230	290	310	350	400	480	600	730	850	980	1100	1250	1450
H(mm)	98	103	108	115	140	150	175	205	245	285	335	415	490	570	580	618	730	890

PN25(DIN 3202-F1)																		
DN(mm)	15	20	25	32	40	50	65	80	100	125	150	200	250	300	350	400	500	600
L(mm)	130	150	160	180	200	230	290	310	350	400	480	600	730	850	980	1100	1250	1450
H(mm)	98	103	108	115	140	150	175	205	245	285	335	415	490	570	580	618	730	890

PN40(DIN 3202-F1)																		
DN(mm)	15	20	25	32	40	50	65	80	100	125	150	200	250	300	350	400	500	600
L(mm)	130	150	160	180	200	230	290	310	350	400	480	600	730	850	980	1100	1250	1450
H(mm)	98	103	108	115	140	150	175	205	245	285	335	415	490	570	580	618	730	890

Noted: The chart above only lists out some common composition of steel strainer parts. We may provided other different parts material composition according to the customer's request or the actual valve working condition.

Service promises

Pre-sales: Before ordering or contracting, you may inquire our price, Specification, Product performance Parameters and set-up equipment via phone or other methods; our sales or Tech. staff will patiently give you a detailed information on your inquiry; furthermore, some corresponding documents may be available on request.

Sales-proceed: During the product manufacture, you can call us at any time inquiring on the product procedure or status; you can also dispatch your staff to our factory for product supervision and acceptance inspection.

After-sales: After finished the product manufacture and packing, normally, we will transport the goods for our customers. We can dispatch our special Tech. Staff to the spot of this product for assembling and adjustment. Meanwhile, our Staff will offer you a detailed explication and guidance on the product usage, maintenance and any other details.



YDB VALVES LLP

An ISO 9001:2015 Certified Manufacturing Co.

Head Office :

Y-21, Khan Real Industrial Estate,
N. H. 08, Pelhar, Vasai Phata,
Vasai East, Palghar - 401208.
INDIA.

Contact us: +91- 80 8701 0270

Write us: info@ydbvalves.com